

The Bell System Technical Journal

Vol. XXV

January, 1946

No. 1

Early Fire-Control Radars for Naval Vessels

By W. C. TINUS and W. H. C. HIGGINS

INTRODUCTION

FOR a number of years before the war a very intensive development effort was under way in the Army and Navy laboratories, and in several commercial laboratories, on the application of radio methods to the location of objects at a distance. The equipment which resulted was eventually called "Radar" equipment by the Navy and this term is now almost universally used. The urgent needs of the war have resulted in the very rapid development and extensive application of this new science during the last few years.

Radar equipments of many different types have been designed to perform specific functions on land and sea, and in the air. These equipments have had an important part in the winning of the war and the recent relaxation in secrecy regulations now permits publishing some of the story. In this present article a description of the Mark 3 and 4 Fire-Control Radars for Naval Vessels will be given, together with a little of the history that preceded their development.

HISTORICAL BACKGROUND

When the Bell Telephone Laboratories began active radar development work early in 1938 an effort was made to set technical objectives for this work that would avoid duplication of the intensive work then under way in the Army and Navy laboratories, and that would advance the art toward the solution, of some of the recognized basic problems. The general objectives were to increase the accuracy of radar measurement of location and to increase as much as possible the operating carrier frequency. The reasons for these objectives are discussed in the following paragraphs.

The state of the art at the time under discussion has been partially described in a recent paper by Maj. Gen. R. B. Colton.¹ The work he described and directed was carried out at the Signal Corps Laboratories at Fort Monmouth, New Jersey and was directed principally toward solving

¹ "Radar in the U. S. Army" by Maj. Gen. Roger B. Colton, published in the *Proceedings of the I. R. E.*, November, 1945.

the ground forces' problems of aircraft warning and searchlight control. At the same time intensive work was being pursued at the Naval Research Laboratory at Anacostia, D. C. under the direction of Dr. A. H. Taylor, Dr. R. M. Page and Mr. L. C. Young. Their work was directed primarily toward developing radar equipment that would be useful aboard ship, and it was from them and from the engineers of the Navy Department that the principal inspiration and guidance for the work described in this paper were obtained.

The first military application in which radar equipment proved its usefulness was in the detection of approaching aircraft. For this kind of application the radar is not required to locate the approaching planes with very great accuracy and the experimental radars of 1938 and 1939 performed this function in quite a useful way. The fact that the first application of radar was a strictly defensive one may account in part for the great interest and support given radar work in England and in this country, while apparently much less radar work was done before the war by the scientists of Germany and Japan. Thus, when radar later became a powerful and versatile aid to offense, the enemy nations found themselves years behind in development.

Very early in their work the men of the Naval Research Laboratory recognized the potential ability of radar to help solve the fire-control problem. Since this problem determined the design of the radar systems to be described later in this paper a brief general discussion of fire control is given here. The term *fire control* refers broadly to the means by which a gun or other weapon is aimed and fused so that, when fired, the projectile will hit or burst near the intended target. A fire-control system includes two major parts: first, a locating device for determining the present position of the target; and second, a computing device which analyzes the present position data, computes the target's course and speed, and the position the target will occupy at the future time when the projectile arrives at that point, and finally furnishes the correct aiming and fusing information to the guns. A modern fire-control system does these things in a continuous manner so the guns remain correctly aimed and can be fired at any time during the engagement.

Before the war the present position of the target was ordinarily determined by optical instruments. Operators tracked the target by controlling their telescopes in such a way that the target remained on the crosshairs in their eyepieces. Thus the azimuth and elevation angles were found. Another operator measured the range to the target with an optical range finder, or indirectly estimated range from the angular extent of the target and its estimated size.

The accuracy of this optical system in determining azimuth and elevation

angles is very good provided the target can be seen clearly. This proviso is a serious limitation under many typical operating conditions. It is frequently difficult to see a target at a range of several miles on account of haze even on a relatively clear day, and at night or in fog or smoke screen the usefulness of a telescope is almost nil. The optical range finder is subject to the same limitations as the telescope and in addition leaves much to be desired in the matter of accuracy and continuity of data even under the best visibility conditions. This is due to the fact that optical range finders are triangulation devices which inherently have accuracy limitations. The need for a long and very stable base line between the prisms of an optical range finder is difficult to meet aboard ship, and the principle of operation makes inevitable a rapidly decreasing accuracy with increasing range. Thus, as the effective range of guns increased, the need for more accurate means for measuring range became more acute.

In its earliest forms radar offered at once a potential means for measuring range with much better accuracy than that of the optical range finder. This was due to the different principle on which radar works. A pulse of radio frequency energy is sent out to the target and the echo signal is received back at the source. The velocity of the waves en route is the same as that of light, and is one of the basic physical constants. To measure range accurately with radar required only the development of techniques for producing short transmitted pulses and for measuring accurately the short intervals of time between the transmitted pulse and the returning echo pulse. Both of these were the kind of problems which yield readily to electronic solutions. The early work in Bell Telephone Laboratories thus included the production of shorter transmitted pulses than were being commonly used, and the development of improved range measuring means.

The second important general objective for the early work at Bell Telephone Laboratories was to devise equipment which would operate at frequencies much higher than had been previously used. The need for higher-frequency operation arose from the fact that for a given size of antenna the beam width decreases with increasing frequency while the gain increases. Narrow beams are required to obtain accurate angular data while increased gain is desirable since it obviously provides increased range for a given transmitter power and receiver noise figure. These factors are illustrated by the curves of Figs. 1A and 1B which show the relationship between beam width, antenna gain and antenna size expressed in wavelengths. The curve labeled "uniform illumination" yields maximum gain and minimum beam width for a given antenna size but produces unwanted side lobes of undesirable amplitude. For this reason the illumination is usually graded over the antenna aperture to reduce minor lobes. The gain

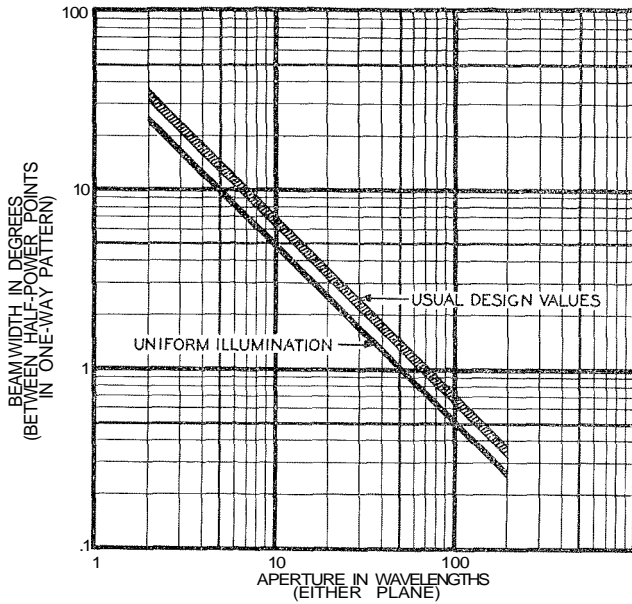

Fig. 1A—Antenna beam width vs. aperture

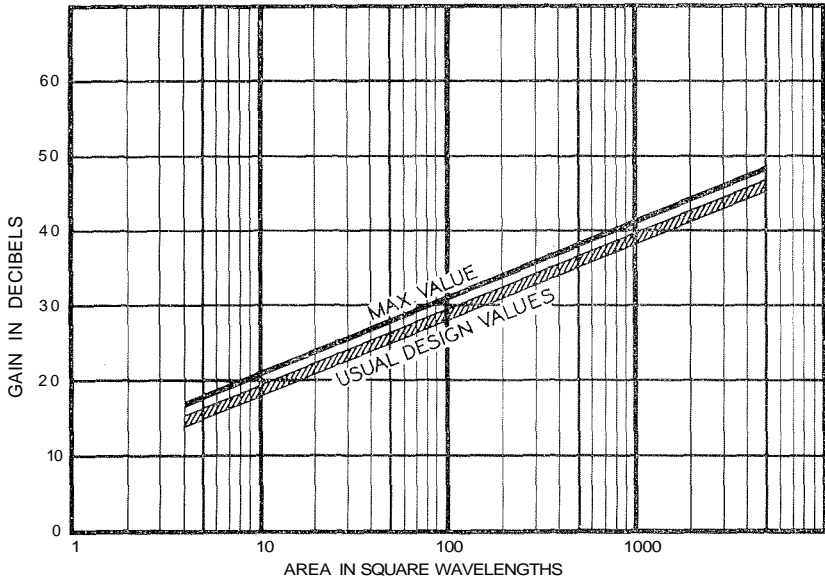

Fig. 1B—Antenna gain vs. aperture

and beam width obtained in this manner are shown by shaded area labelled *usual design values*. The need for higher frequency or shorter wavelength

was apparent to all of the early experimenters since physical limitations restricted the size of antenna which could be installed conveniently aboard ship. However, development effort along these lines had previously been hampered by lack of suitable vacuum tubes.

In spite of the vacuum tube difficulties the Laboratories work was started in the range from 500 to 700 mcs, a region several times that then in use at the Army and Navy laboratories. The best tubes available were those of the *doorknob* type which have been described in the literature by A. L. Samuel² and are illustrated in Fig. 2. The smallest of these was used in the receiver input circuits and two of the middle sized ones were used in the transmitter oscillator. These triodes operated at quite high frequencies by virtue of the very small spacing between their electrodes, a feature which made them fragile and demanded the development of plate modulation. Earlier radars had generally used grid keyed oscillators, i.e., the plate voltage was applied to the oscillator continuously together with a high grid bias voltage. The bias was removed momentarily by the keyer to emit a pulse. In order to obtain a useful pulse output from the doorknob oscillator tubes it was found essential to remove all stress from them except during the pulse. This was accomplished by using a direct coupled pulse amplifier or modulator, effectively in series with the oscillator and the power supply. Here again in 1938 no really suitable tubes were available for the modulator service since it also demanded a highly intermittent duty. However, since the modulator duty did not require the tubes to operate at very high frequency it was possible to use rugged high-voltage triodes which had been designed for continuous service, and to obtain the required pulse current capacity by paralleling a number of tubes. The earliest radar modulators used in the Laboratories employed a group of Eimac 100-TH tubes. Later, in the CXAS and Mark 1 Radars, six tubes similar to the W. E. 356A were used in parallel.

After a great deal of laboratory work an experimental equipment was assembled and demonstrated to the Army and Navy in July 1939. This early radar was notable in that it operated at what was then considered a very high frequency and also in that it employed a single antenna only about 6 ft. square. The transmitter and receiver were connected to the common antenna by a *duplexing technique* to be described later, which had been applied at lower frequencies by engineers at the Naval Research Laboratory. The results of these first field tests were encouraging and both the Army and the Navy ordered one prototype model equipment to be known as the CXAS. This radar was to operate at 500 or 700 mcs and was to incorporate a number of new features which were designed to make it

² *Proceedings of I. R. E.*, Vol. 25, page 1243, 1937—"Negative Grid Triode Oscillator and Amplifier for Ultra High Frequencies." Digest in Oct. 1937 *B. S. T. J.*

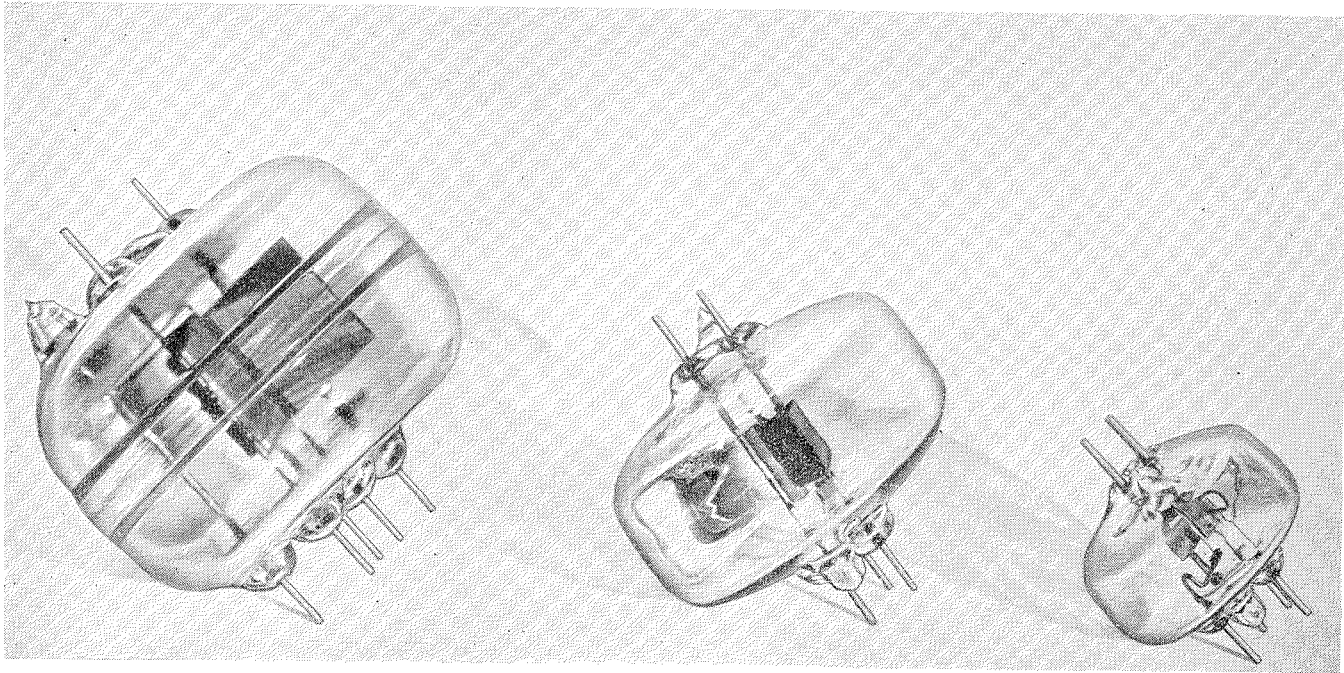

Fig. 2—Vacuum tubes for ultra-short waves

convenient to operate and to provide a range accuracy that would be useful in fire control. Since this early radar is of considerable historical importance it will be described in some detail.

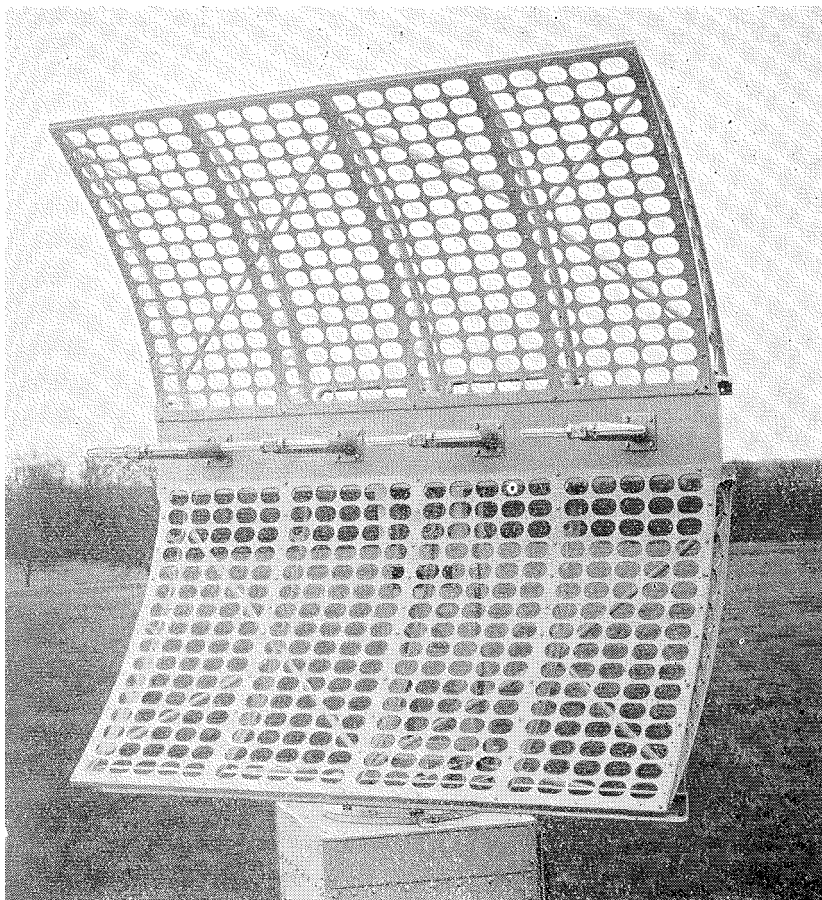

Fig. 3—CXAS—Antenna

THE CXAS RADAR

This equipment was divided into three major assemblies and the circuits were arranged so the three could be installed at some distance from each other. The antenna (see Fig. 3) consisted of a cylindrical parabolic reflector about 6 ft. square with an array of eight half-wavelength dipoles along the focal line. With shipboard use in mind the reflector was perforated to minimize wind resistance and the dipole and coaxial line feed

system was made weatherproof, which was accomplished by making the line system pressure-tight and filling it with dry gas. The gas-line system was extended to include the radiating elements by covering the latter with pyrex test tubes sealed to the support with a packing gland as shown in Fig. 4. A device was included in each dipole assembly for supplying the two half-wavelength radiating elements with balanced voltages from the unbalanced line, while a coaxial line harness including impedance matching

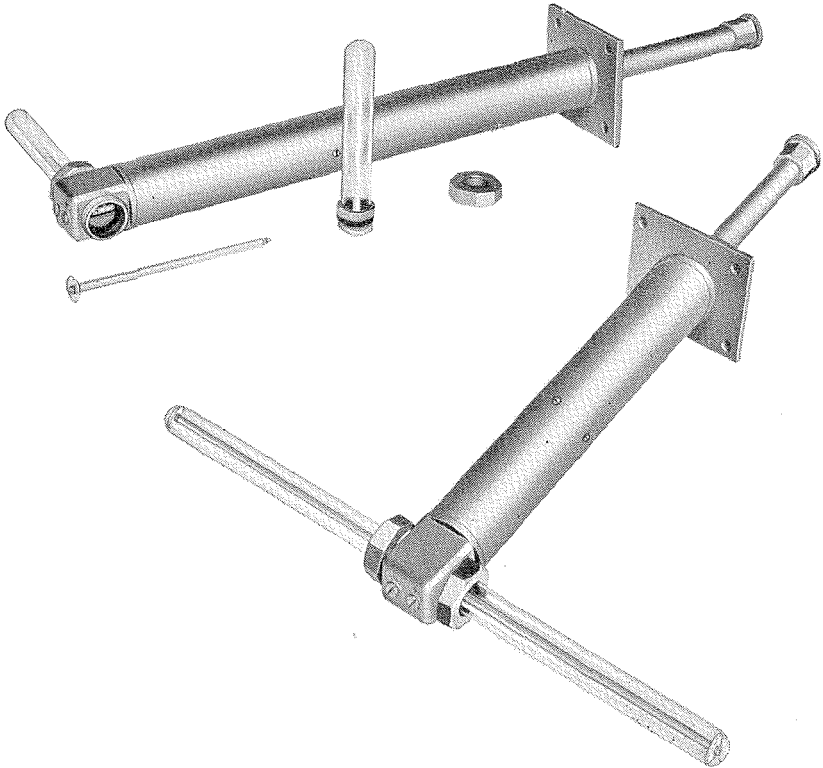

Fig. 4—CXAS—Dipoles

transformers was used to connect the several dipole assemblies and provide a matched load to the single transmitter-receiver line. A schematic diagram of this arrangement is shown in Fig. 5. The contemplated use of this radar was for surface targets or low-flying planes and rotation was provided only in azimuth. A gas-tight rotary joint was developed to carry the 7/8" coaxial line through the azimuth axis (Fig. 6),

The operator's cathode ray oscillograph indicator and all of the essential

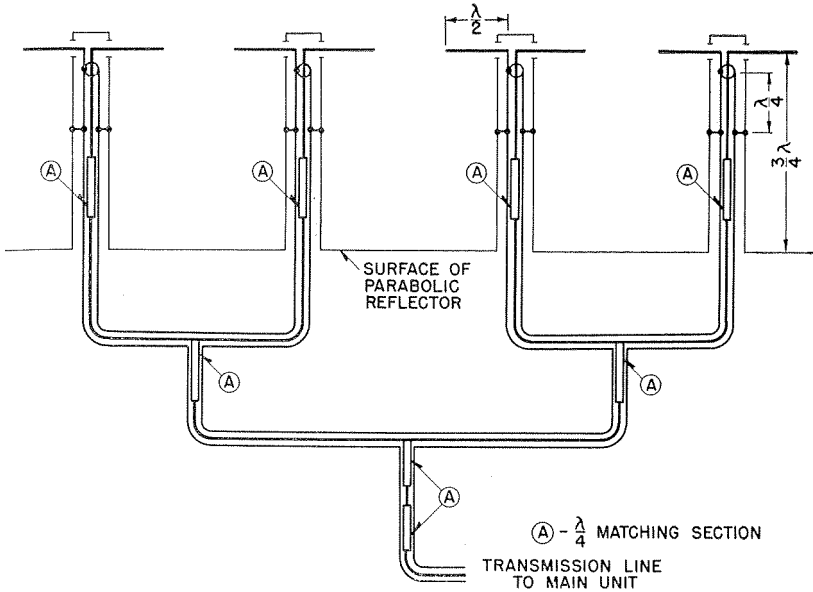

Fig. 5—CXAS—Antenna schematic

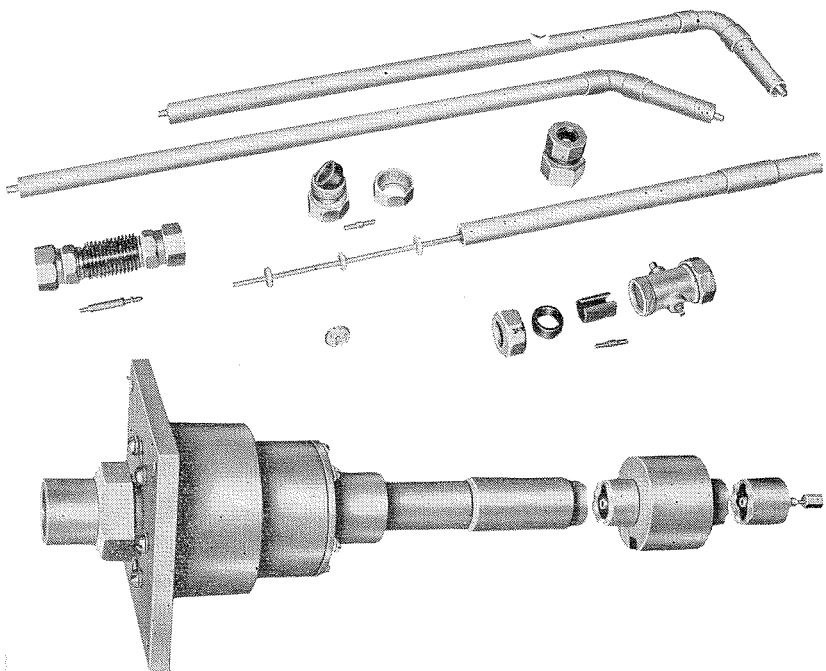

Fig. 6—CXAS—Rotary joint & transmission line fittings

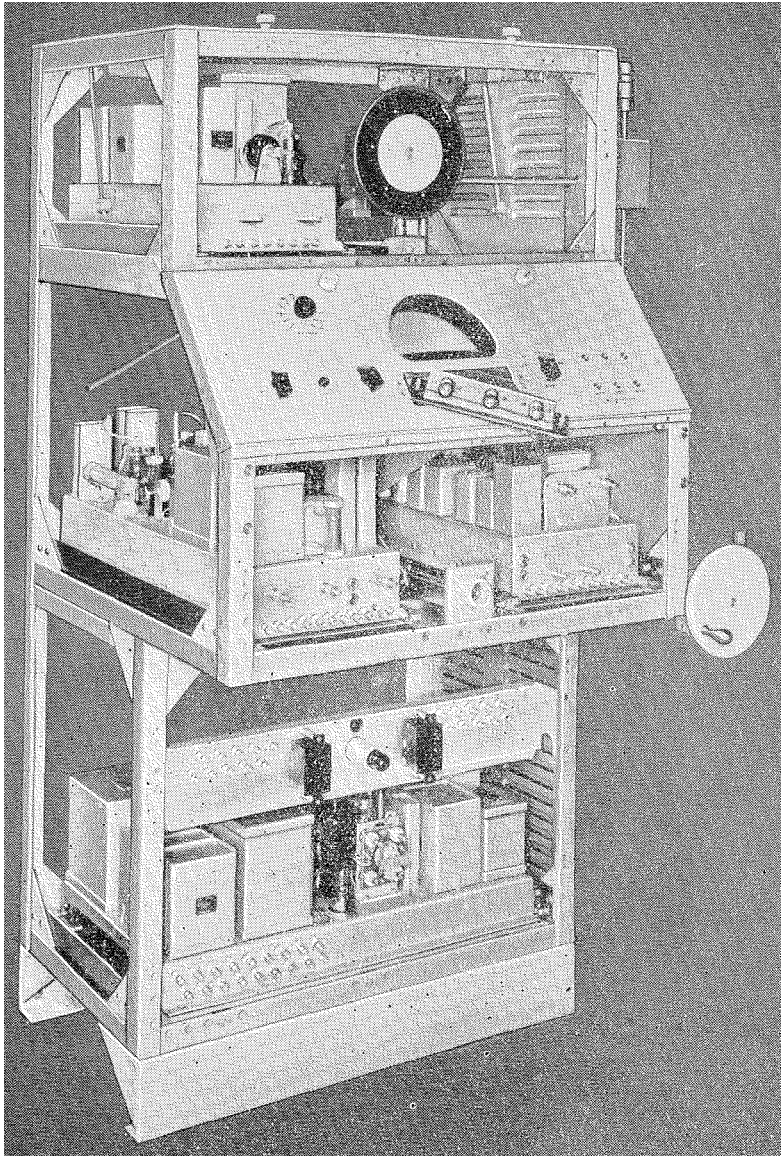

Fig. 7—CXAS—Indicator desk—covers removed

operating controls were combined into an assembly called the Indicator Desk, a photograph of which is shown in Fig. 7. This was intended for indoor mounting below the antenna in such a position that the azimuth

hand wheel on the desk could be connected to the antenna turntable by a shaft. The indicator employed a 7" cathode ray tube and displayed the radar signals by what is now known as a Class A sweep with a full scale of 100,000 yards. A pioneering feature of this indicator was the provision of a series of electronic range marks to increase the accuracy with which target range could be read. Earlier indicators had used a ruled mask for the range scale and had suffered in accuracy due to parallax, sweep non-linearity, drift of sweep position, etc. The CXAS provided sharp pulses to mark the 10,000-yard intervals along the sweep line, and smaller pulses to mark the intervening 2,000-yard intervals. This system was free from the errors of the ruled mask and permitted range readings accurate to ± 200 yards throughout the 100,000-yard scale. Provision was also made to expand any desired 20,000-yard segment of the scale to fill the entire tube screen so that signals could be examined more closely. The ranges corresponding to the 10,000-yard intervals were designated by illuminated

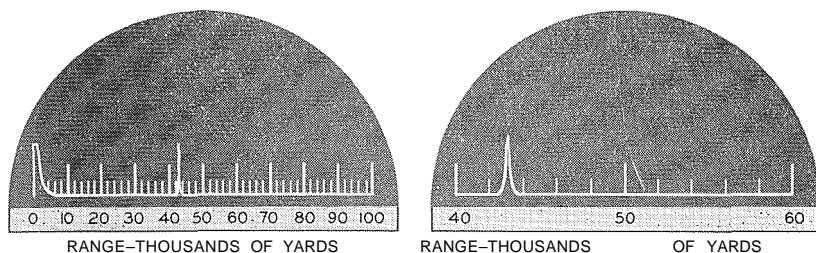

Fig. 8—CXAS—Range mark system

numerals located directly below the electronic scale. The presentation obtained with this arrangement is indicated in Fig. 8 which shows the electronic calibration marks, transmitted pulse, and an echo at 43,000 yards on both the full and expanded scales.

The third part of the CXAS equipment was an assembly known as the Transmitter-Receiver or Main Unit. It was designed to be unattended in normal operation and contained the Pulse Generator, Radio Receiver, Power Control Panel, Radio Transmitter, and H.V. Rectifier, which were all built as removable *drawer type* units. A side compartment in the Main Unit also housed the duplexing circuits, gas equipment for the transmission line, and some built-in test equipment, including a wavemeter and monitoring rectifier. The Main Unit and its sub-units are shown in Figs. 9 to 14, respectively. A single 7/8" coaxial transmission line provided connection from the Main Unit to the antenna.

In order to use a single antenna for both transmission and reception, means had to be provided to effectively disconnect the receiver during the

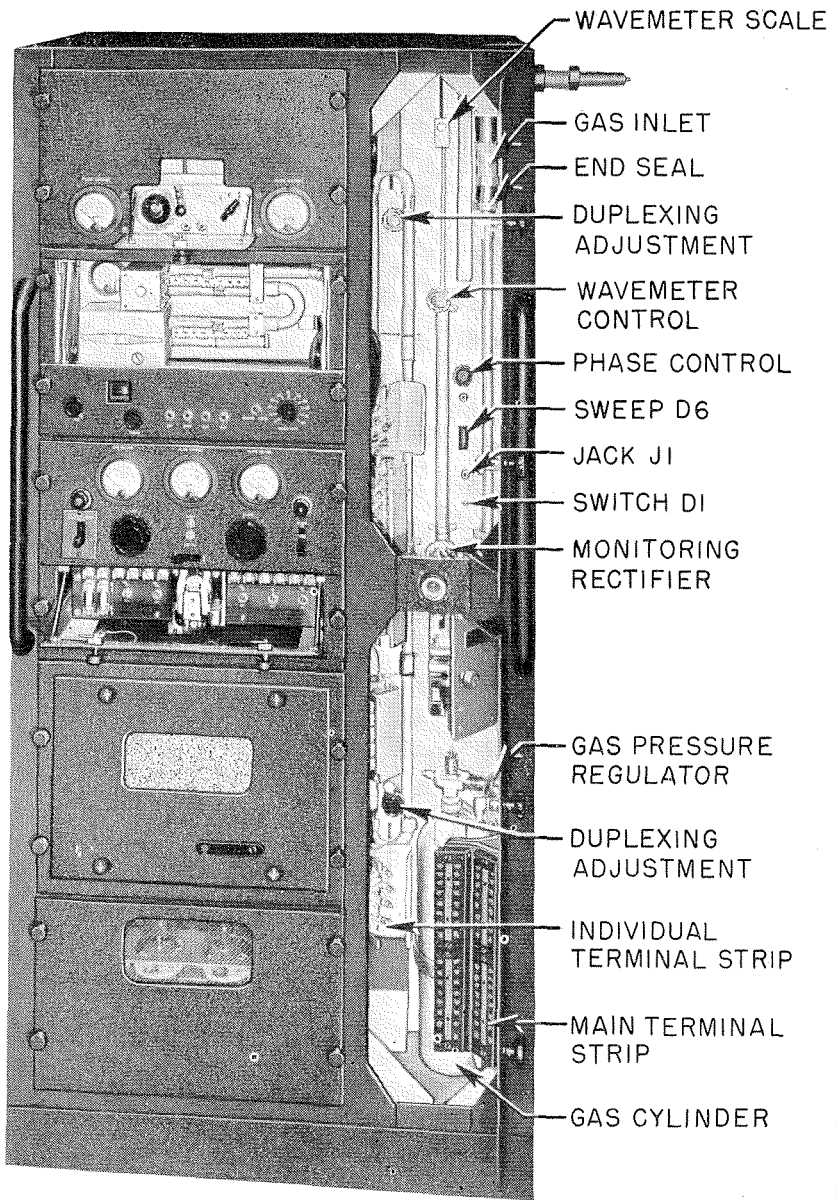

Fig. 9—CXAS—Main unit

transmitted pulse and to effectively disconnect the transmitter when the echo is received. If this were not done, a large part of the transmitted

energy would be dissipated in the receiver. Also, the minute received energy would be partially lost in the transmitter output circuit thus reducing the maximum range. Because of the extremely short time intervals between transmitted and received pulses, ordinary switching methods cannot be used. A *duplexing technique* mentioned earlier was therefore developed to provide this function. In the CXAS Radar this switching was obtained by connecting the transmitter and receiver to the antenna transmission line through adjustable lengths of coaxial line which were preset for a given operating frequency to be effectively an odd multiple of

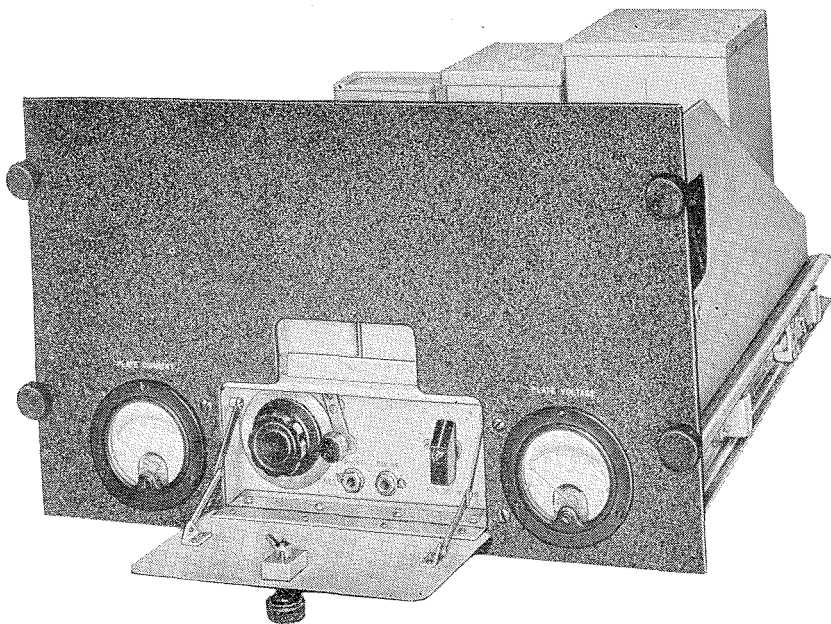

Fig. 10—CXAS—Modulation or pulse generator

one-quarter wavelength long. During the transmitted pulse, a small amount of the transmitted power overloaded the first tube in the receiver and provided a low impedance at that point. Due to the line length between receiver and junction point this low impedance is reflected as a high impedance at the junction point with the result that very little power is lost in the receiver line. At the end of the transmitted pulse the output impedance of the transmitter consists only of the small inductance of the output coupling loop and this impedance is reflected by proper choice of line length as a very high impedance at the junction joint with the receiver line. Thus, most of the received echo is directed to the receiver input

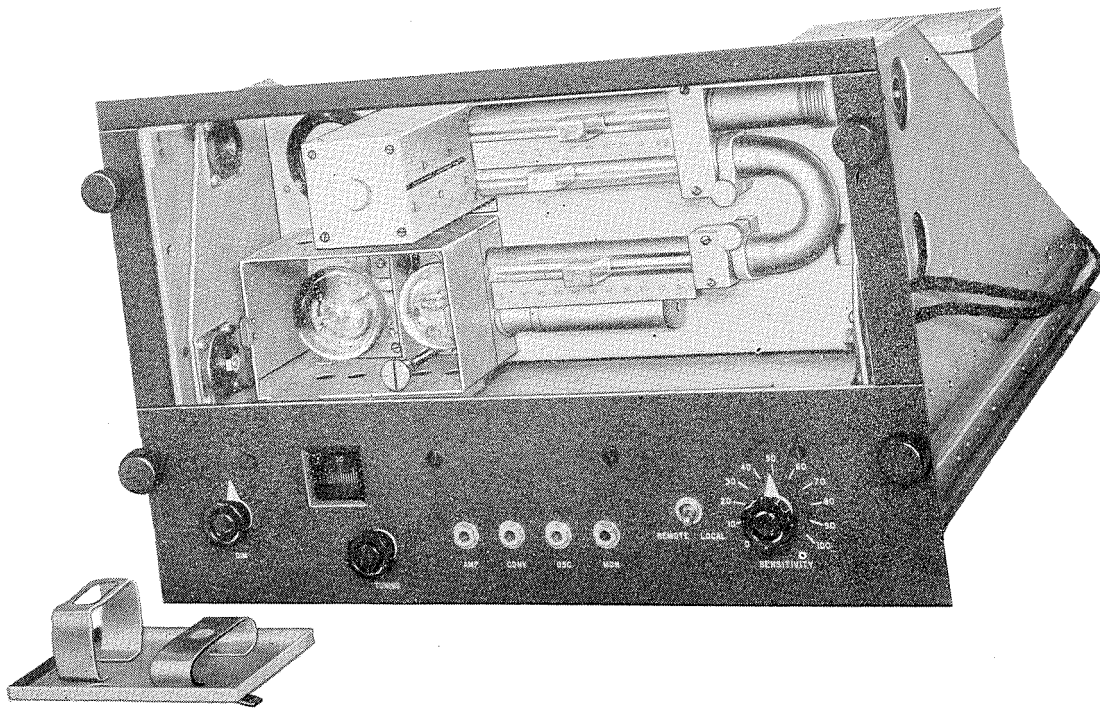

Fig. 11—CXAS—Receiver

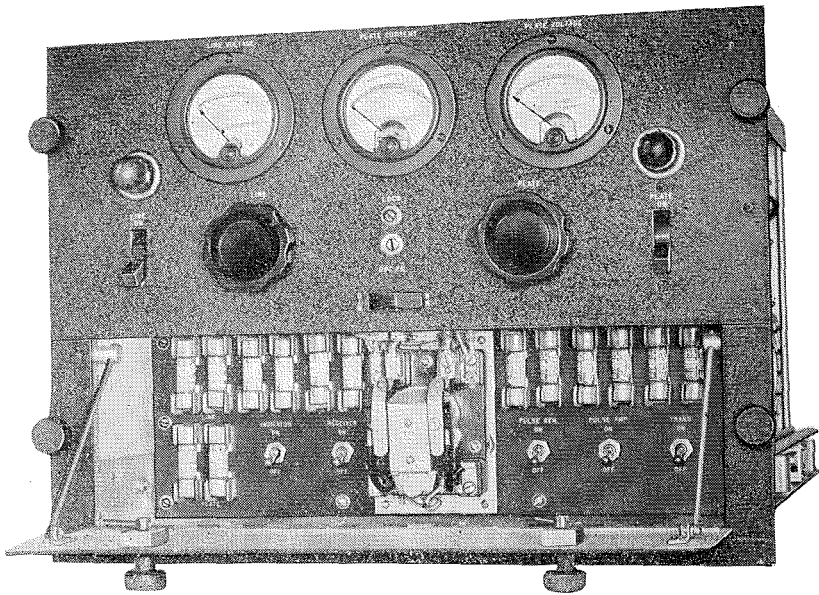

Fig. 12—CXAS—Power control panel

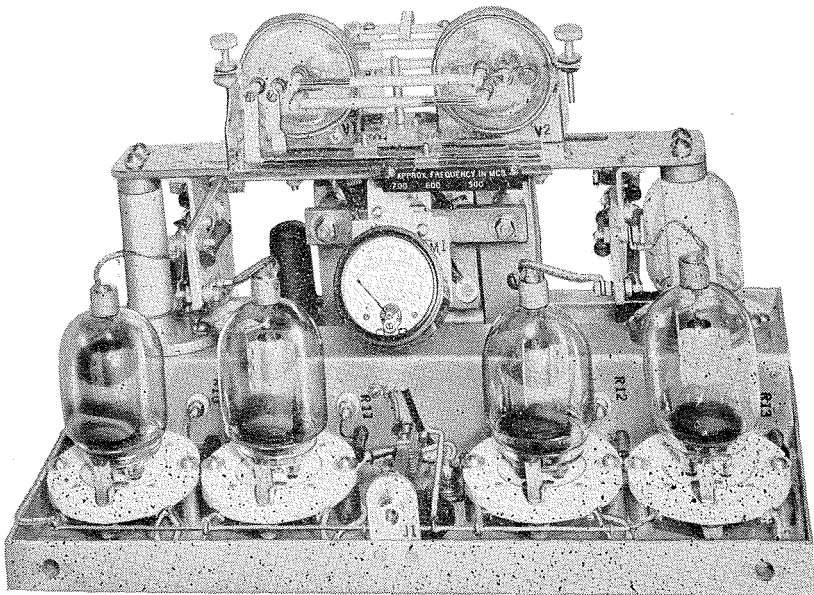

Fig. 13—CXAS—Transmitter

circuit. The adjustable duplexing transmission lines may be seen in the side compartment of the Main Unit on Fig. 9.

The equipment just described could be operated over a small frequency band of about 40 megacycles in the neighborhood of either 700 or 500 megacycles. The transmitter, receiver, and duplexing circuits were tunable over the entire range, but it was necessary to set up the antenna for one band or the other. This was accomplished by installing the proper one of the two sets of dipoles furnished, and installing or omitting a set of wedges

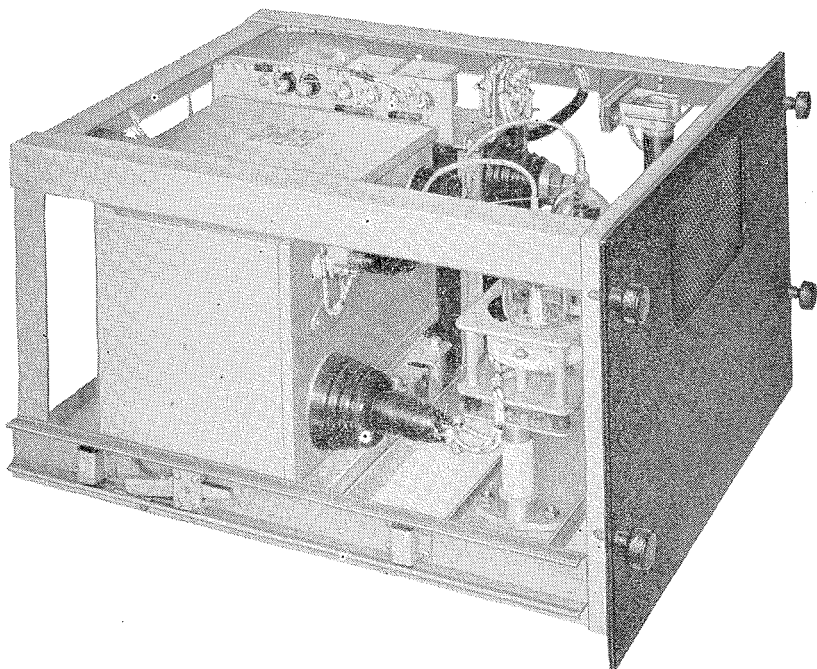
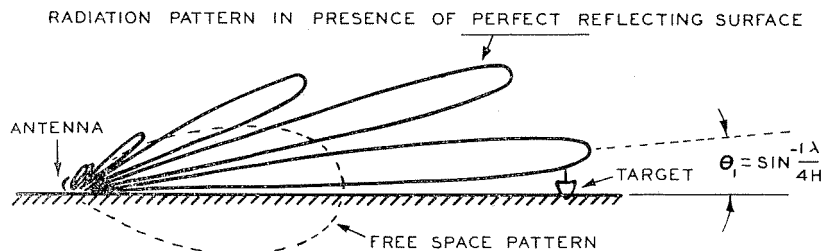

Fig. 14—CXAS—High voltage rectifier

which tilted the reflector wings to change the parabola focal length. This antenna set a precedent in design in that the dipoles and coaxial harness were designed for fairly broadband operation and were entirely free from field tuning adjustments which had been very troublesome in earlier equipment.

The CXAS Radar was demonstrated to the Navy in December 1940. After a few tests it was decided by the Navy to standardize on the 700-megacycle band. One of the principal reasons for this was that the tests had proved the superiority of shorter waves for surface target work; the

CXAS having regularly out-performed much higher powered equipment operating at 100 or 200 megacycles for this service. The reason for this can best be understood by reference to Fig. 15 which illustrates what happens when a radio beam is directed horizontally over water. The beam breaks up into an interference pattern of several rays due to reflection from the surface; the position of the lowest ray depending only upon the height of the antenna measured in wavelengths above the water. Since the mount-



$$G = 2 \sin \left(2\pi \frac{H}{\lambda} \sin \theta \right) \times \left[\text{FREE SPACE ANTENNA PATTERN} \right]$$

- WHERE H = ANTENNA HEIGHT
 λ = WAVE LENGTH IN SAME UNITS AS H
 θ = ELEVATION ANGLE IN DEGREES
 G = RELATIVE FIELD STRENGTH

Fig. 15—Effect of surface reflection on elevation beam

TABLE I

Operating Frequency.	Tunable 680-720 mcs.
Antenna.	Dipole array of 8 half-wave radiators, reflector 6' x 6', beam width 12 degrees, gain 22 db.
Transmitter Pulse Power.	Approximately 2 kw.
Pulse Repetition Rate.	1640 PPS
Pulse Duration.	Variable in 5 steps from 1 to 5 microseconds.
Receiver-Superheterodyne.	1 mc bandwidth, 30 mc IF frequency.
Receiver Noise Figure.	Approximately 24 db.
Range Calibration.	Electronic marks at 10,000 and 2,000 yard intervals.

ing height available aboard ship is fixed, the use of shorter wavelengths made it possible to keep the lowest ray more nearly horizontal where it could intercept a target's superstructure at greater distance.

The principal characteristics of the CXAS Radar as set up for operation at 700 megacycles are given in Table I.

This equipment gave useful results on surface targets at ranges of 10 miles or more (depending on the size of the target) and the range accuracy

of about ± 200 yards was then considered very usable in surface target fire control. The target azimuth could also be determined to a precision of one or two degrees by rapidly swinging the antenna back and forth and observing the point which gave a maximum echo signal. This angular information was hardly good enough for fire control use. The equipment was also of some use against low flying aircraft as a means of getting better range data for fire control. Minor equipment difficulties were not entirely solved; in particular the doorknob triodes in the transmitter had a very short life under the high voltage pulse operating conditions. They had, of course, been designed originally for CW communication use and strenuous development effort to make them more suitable for the intermittent high power radar use had not been very successful.

THE MARK 1 RADAR

In spite of the obvious unsolved development problems the Navy immediately ordered 10 equipments, similar to the CXAS, for use in the Fleet. These were first called the FA Radio Ranging Equipment but the designation was later changed to Radar Mark 1. Several changes were made to better adapt the equipment for installation aboard ship, the principal one being a servo driven antenna pedestal of the amplidyne type which was furnished by the General Electric Company. The servo system eliminated the antenna drive shaft problem while retaining control from a handwheel on the control desk. The desk was also modified to provide dials reading both relative and true azimuth bearing, the latter being obtained by interconnection with the ships gyro compass system.

The first Mark 1 Radar was shipped by the Western Electric Company in June 1941 and installation on the USS Wichita was completed at the Brooklyn Navy Yard early in July 1941. This was the first fire control radar in our Fleet and the first of many thousands of radars of all types which the Western Electric Company was destined to build for the Navy in the following four years.

THE MARK 2 RADAR

While the ten Mark 1 radars were being built, development work was proceeding at top speed on major improvements designed to increase performance, eliminate operating troubles, and to make this new device fit better into the existing fire control situation aboard ship. The older optical devices were neatly integrated into a system, many features of which were automatic. For example, the gyro stabilized telescopes and optical range finder were assembled into a compact rotating armored box called a *director*, located high on the ship. Target data from the director was sent

automatically by *synchro* data transmitters to the computer below decks, which solved the fire control problem and likewise transmitted automatically the correct information to the guns. For the new radar target locating device to fit into the existing system it was necessary to make its angle finding function operate more in the manner of the telescopes. Not only was it desired to determine target angles more accurately but it was necessary to track target position continuously and smoothly. Finally, to take care of the anticipated need for rapidly changing back and forth during an engagement from optical to radar data it became apparent that the same operators should handle both jobs. Thus it was decided that the system should provide the existing operators with oscilloscopes to supplement their telescopes, and to arrange them so either could be used as desired. Further to coordinate the data it became obvious that the radar antenna should be connected with the optics in such a way that the two were always pointed in the same direction. This would make it possible to leave the existing data transmission system alone and would avoid any break in data when changing from optics to radar or vice versa. For example, if a visible target disappeared behind a fog bank the telescope operator would simply move his head to look at his oscilloscope and data would continue to flow smoothly to the computer and to the guns.

Thus the engineers of the Navy decided the new radar device could be fitted into the existing fire control system. Any other decision would likely have required modification of many parts of the system, and would have delayed the extensive use of fire control radar by a matter of years. The Bell Telephone Laboratories were accordingly asked to modify and improve the radar design to make possible the coordination of optics and radar as just discussed. The new radar was to be called Mark 2 and was to be similar to the Mark 1 but modified to provide continuous tracking in azimuth with an accuracy of ± 15 minutes of arc, and continuous tracking in range with an accuracy of ± 50 yards. Further, the operator's oscilloscopes and controls were to be put into small units that could be mounted alongside of the telescopes in the director, and the antenna was to mount on the director. These requirements demanded some important forward steps in radar development which will be described in some detail. Before Radar Mark 2 got into production a much higher powered transmitter was developed and with this change the equipment was re-named Radar Mark 3.

THE MARK 3 RADAR

The general arrangement of apparatus for this radar differed from the Mark 1 principally in the indicators, which were designed to mount in the

already crowded gun director. These indicators are shown in Figs. 16, 17 and 19. Fig. 16 shows the range operator's oscilloscope, called the Control and Indicator, which was located near the optical range finder. Adjacent to this unit was mounted the range unit, shown in Fig. 17 by means of which the operator could select the target to be followed and continuously

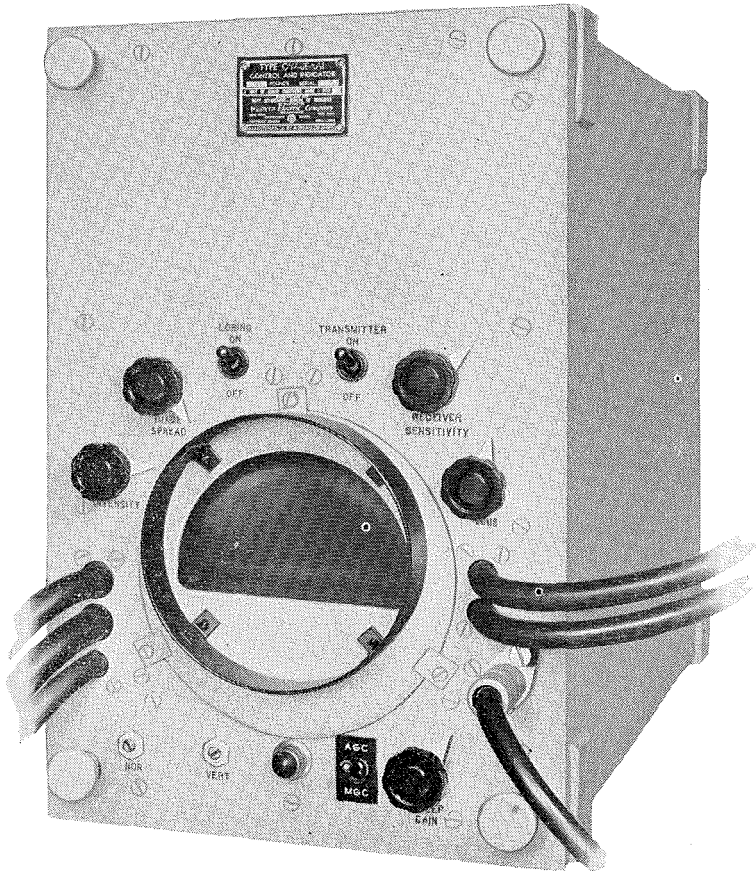

Fig. 16—Control & indicator—Radars Mark 2, 3 & 4

maintain accurate range readings. A typical installation of these two units is shown in Fig. 18. The third unit, shown in Fig. 19, is called a Train or Elevation Indicator and, in Radar Mark 3 (which was for surface fire only) this indicator was mounted adjacent to the Train (azimuth) Operator's telescope.

In addition to the Train Indicator, the azimuth operator was provided

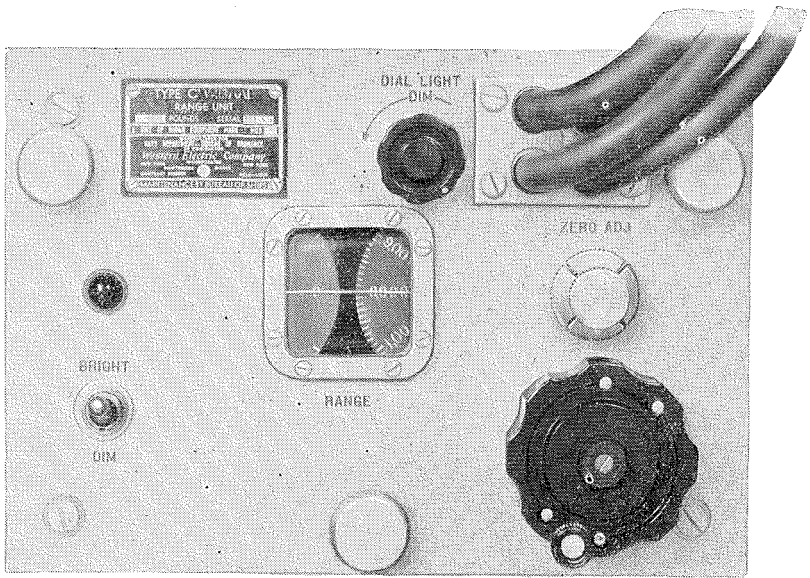

Fig. 17—Range unit—Radars Mark 2, 3 & 4

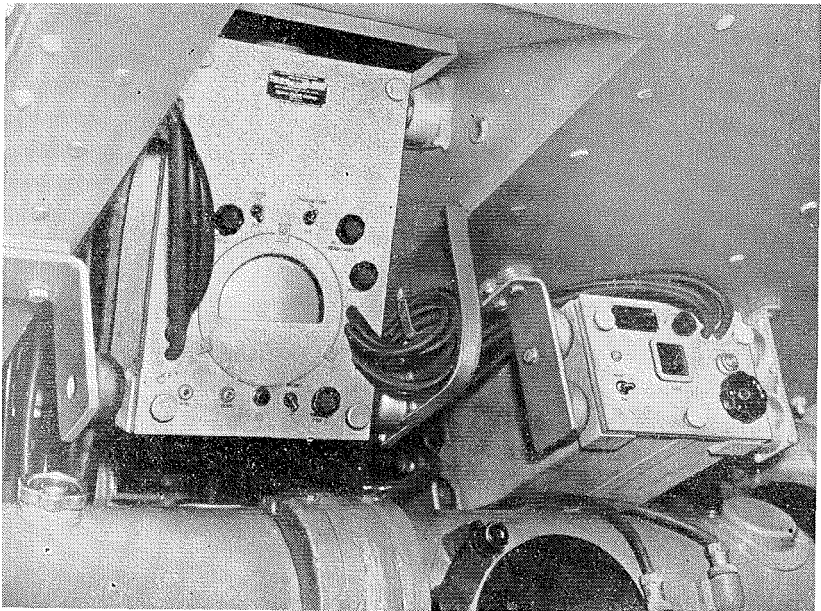

Fig. 18—Mark 3 Radar—Range operator's position on Cruiser Honolulu (Navy Photo 153-6-42)

with a Train Meter of the zero center type which indicated the direction of deviation from true target position. One of these meters of early design can be seen in Fig. 38. Two meters of later design are shown in Fig. 39 mounted immediately below optical telescopes. The pulse generator, receiver, transmitter, rectifiers, etc., were located below decks in the Trans-

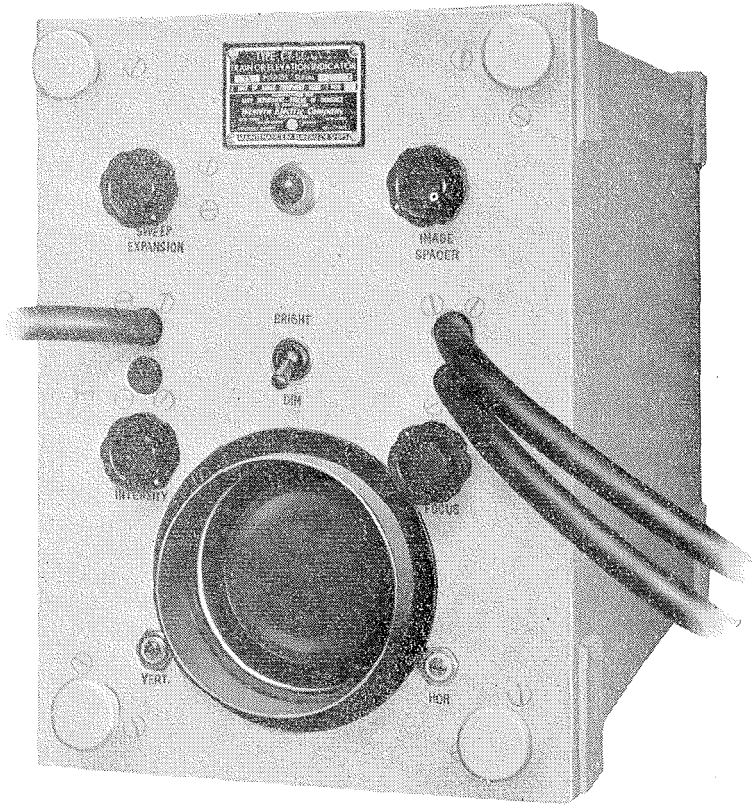

Fig. 19—Train or elevation indicator—Radars Mark 2, 3 & 4

mitter-Receiver, or Main Unit which was very similar in appearance to the Main Unit of Radar Mark 1 shown in Fig. 9.

Two types of antennas were provided for this radar: a 6 ft. by 6 ft. parabolic array similar to the Mark 1 antenna, and a 3 ft. by 12 ft. parabolic array. Either one or the other of these antennas was mounted on top of the gun director and rotated with it in azimuth. Both were provided with azimuth lobe switching to be described later. Because of the relatively narrow elevation beam of the 6 ft. by 6 ft. array, this antenna required gyro

stabilization in elevation to take care of pitch and roll of the ship. Such stabilization was not required with the broad elevation beam obtained with the 3 ft. by 12 ft. antenna; and in addition, this wider antenna provided more accurate tracking due to the narrower antenna beam in azimuth. Installations of these antennas aboard ship are shown in Figs. 20 and 21 and 22, 23 and 24.

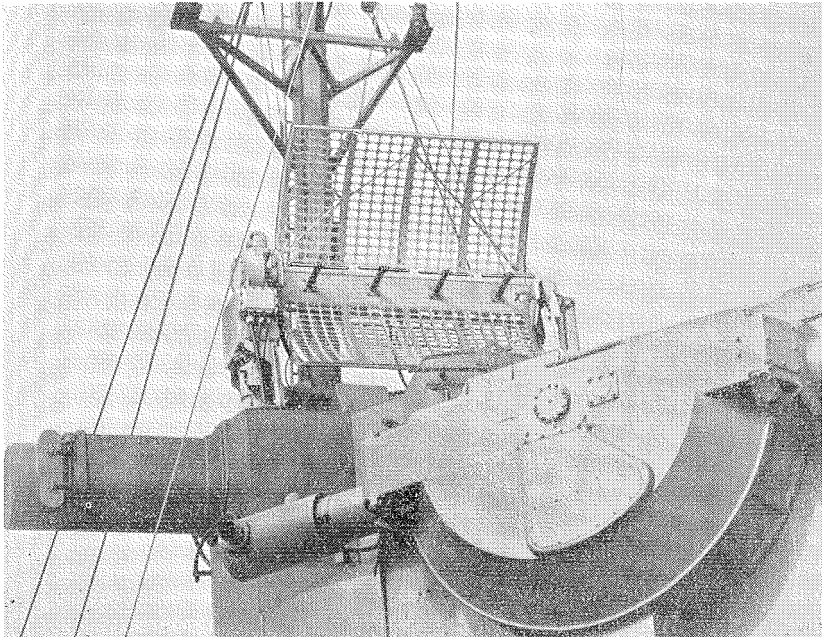

Fig. 20—Radar Mark 3 antenna (6' x 6') on Cruiser Honolulu (Navy Photo 144-6-42)

Antenna Lobe Switching

The problem of measuring angles accurately with a relatively broad radio beam has been faced many times in the radio direction finding art. The most successful attack has made use of the fact that while the nose of a radio antenna beam is blunt, the sides of the beam are relative!}- steep; i.e., while the rate of change of signal amplitude with angle is very low near the nose of the beam it becomes substantial down on the side of the beam. A very well known application of this principle is the airway radio range wherein two very broad overlapping beams define a narrow path by utilizing the points where the two overlap with equal intensity. A somewhat similar scheme in which the antenna beam is switched rapidly between two positions has been applied in radar, and in an early form was first used

in this country by the Signal Corps in the work described by General Colton, to which reference has been made.

The use of two antenna beam (or lobe) positions to obtain more accurate radar angle data is referred to as *lobe switching* and the operating principle is illustrated in Fig. 25. The antenna beam is shown in two positions: position 1 being directed to the right, and position 2 to the left of the mechanical axis of the antenna. The antenna beam is caused to switch rapidly between these two positions, and simultaneous with this switching a small horizontal displacement of the indicator Class A sweep is introduced. In

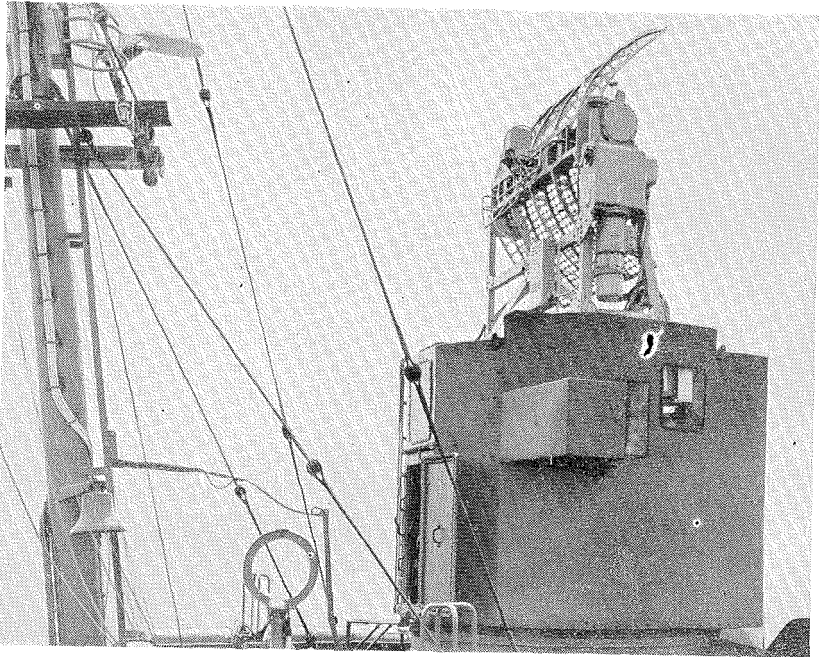

Fig. 21—Radar Mark 3 antenna on Destroyer Porter (Navy Photo 2711-42)

this manner the signals received in the two beam positions may be viewed separately. The speed of switching is made sufficiently high to minimize flicker and the effect of fading signals. It will be noted from this diagram that the signal strength received from target A is the same for both beam positions thereby producing equal “pip” heights on the indicator screen. However, for target B the signal amplitude is greater in position 1 than in position 2 and the “pip” amplitudes on the indicator differ correspondingly. If the operator wishes to track target B it is only necessary for him to rotate the antenna until the two “pips” are of equal amplitude. Smooth

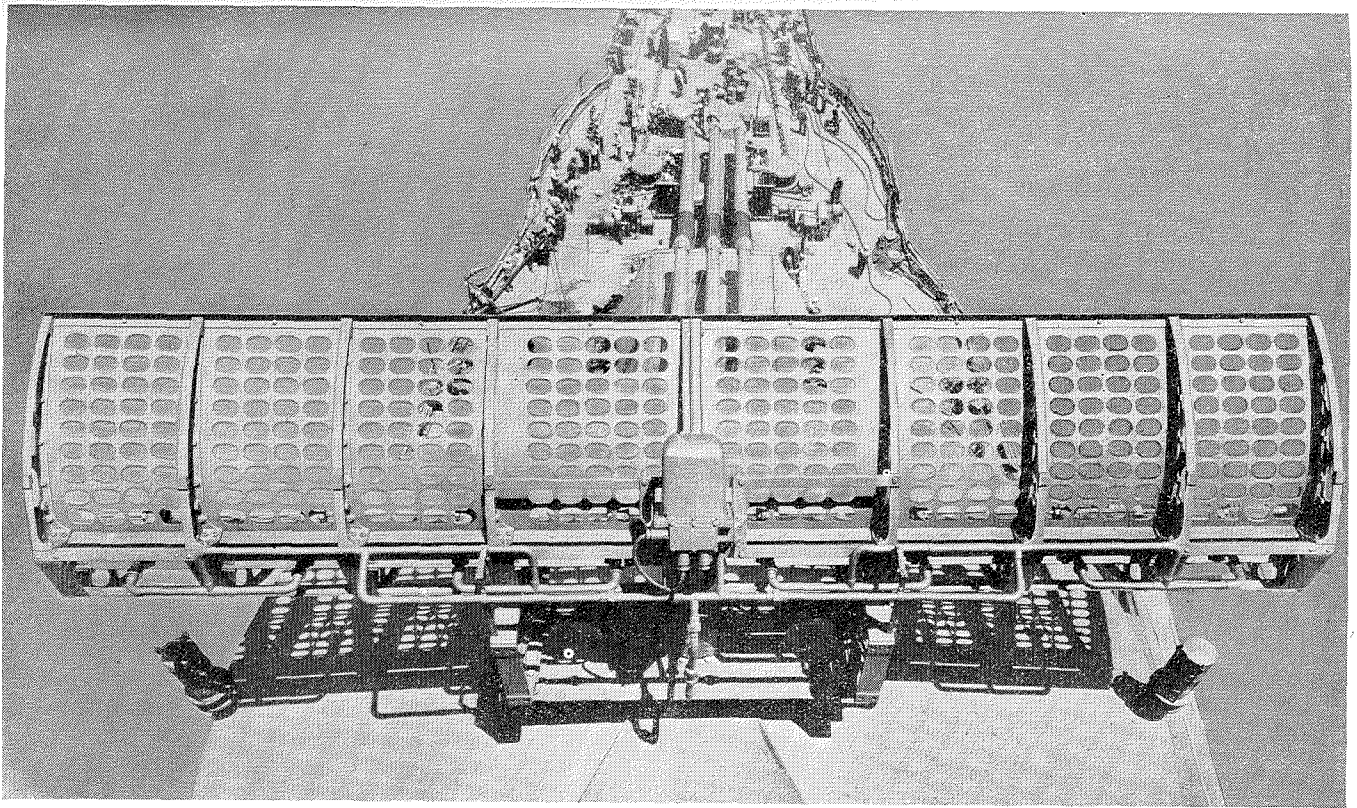

Fig. 22—Radar Mark 3 antenna (3' x 12') on Battleship Pennsylvania (Navy Photo 4273-42)

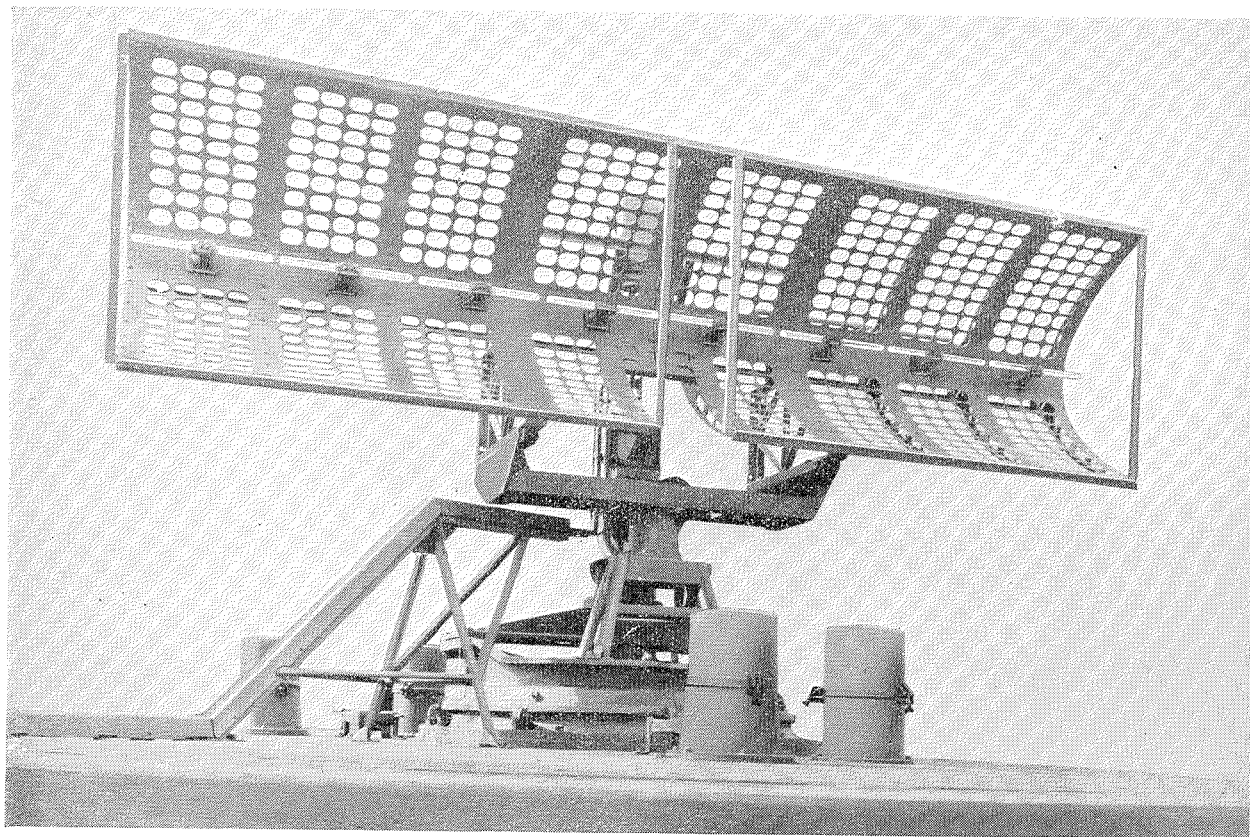

Fig. 23—Radar Mark 3 antenna (3' x 12') on Battleship New Jersey (Navy Photo 181812)

flow of azimuth data will be obtained if the operator continuously maintains equal amplitude of the two "pips".

In the Signal Corps equipment to which reference has been made, separate antennas were used for transmission and reception with lobe switching

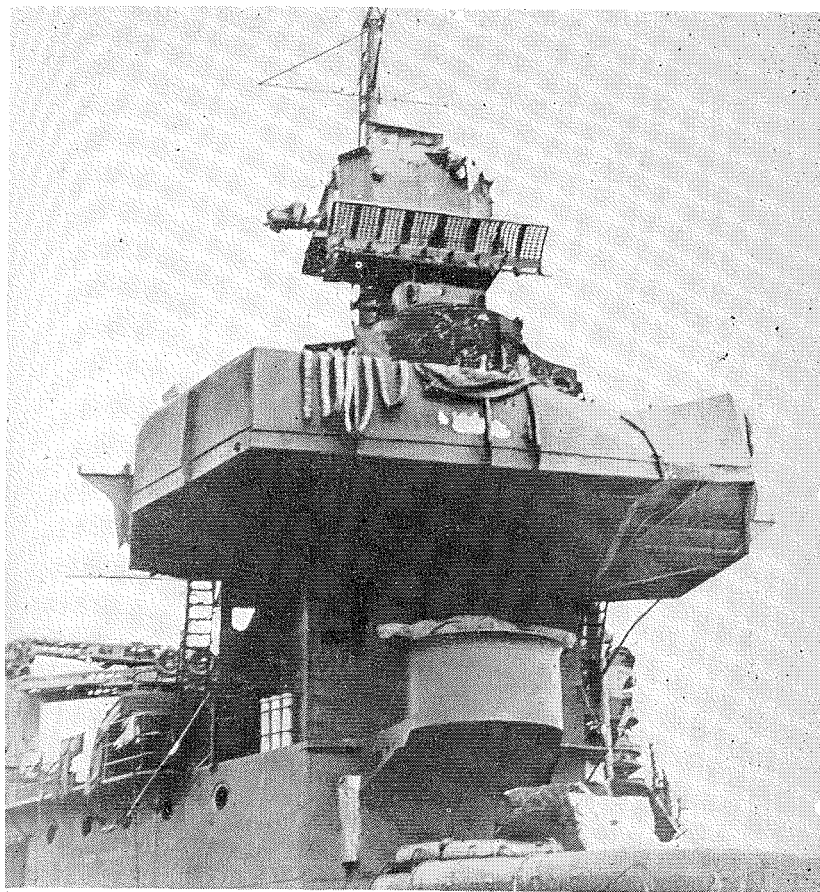

Fig. 24—Radar Mark 3 antenna (3' x 12') on Cruiser San Francisco after Pacific battle (Navy Photo 34133)

applied only to the receiving antenna. Space limitations aboard ship made it mandatory to accomplish all functions using a single antenna. This required the development of a lobe switching device capable of withstanding the high peak power during the transmitted pulse; a problem which had not been faced in the Signal Corps equipment. It was further desired to provide a weatherproof lobe switching device, free from radio

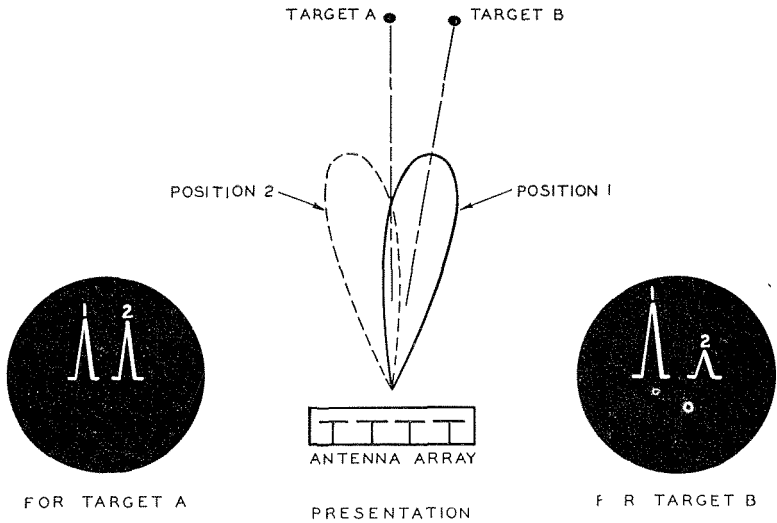

Fig. 25—Principle of lobe switching

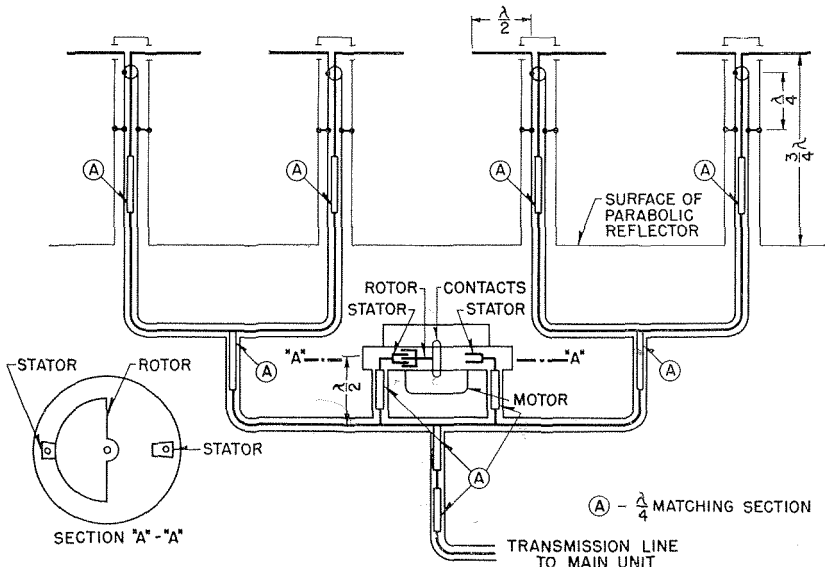

Fig. 26—Mark 2 & 3—Antenna schematic

frequency adjustments, in order to simplify operation and maintenance. The manner in which these objectives were met is described below.

To obtain lobe switching of the antenna beam, use was made of the fact

that the beam position depends upon the relative phase of the excitation applied to the radiating elements of the array. If all elements are excited in phase, as in Radar Mark 1, the beam will be normal to the line of the array, while gradually increasing phase difference across the array will result in displacement of the beam. For small angles of beam shift, entirely satisfactory results may be obtained by shifting the phase of excitation applied to one-half of the array with respect to the other, and this expedient results in a much simpler phase shifting mechanism than would be required to obtain uniform phase change. This system was used in Radar Mark 3 and its application is illustrated schematically in Fig. 26. It will be seen that this array is identical to that used for Radar Mark 1 except for the central section of transmission line in which a lobe switching unit has been added. In this unit the phase of excitation to one-half of the array is retarded with respect to the other half by connecting a capacitive reactance alternately across one feed line or the other to obtain the two beam positions. Switching is accomplished by the use of a motor driven rotary capacitor shown Section A-A. The rotor is a semicircular aluminum casting which is maintained at substantially ground potential by very close spacing to the grounded metal housing. The two stators are small metal plates which interleave with the rotor during approximately one-half revolution and are connected through half-wavelength coaxial lines to the antenna transmission lines. The purpose of the half-wavelength stub lines is to avoid physical limitations which would otherwise be encountered in connecting the rotary capacitor to the lines. Allowance is made in these stubs for end-loading caused by stray capacitance of the stator plates and supporting insulators. It will be seen that during nearly one-half revolution of the rotor one of the stators is engaged to shift the antenna beam in one direction while during the other half revolution the other stator is engaged to produce the other lobe position. The switching occurs during the small interval in which both stators are engaged by the rotor. Signals received during this interval are blanked out in the indicator. The rotor of the lobe switcher is driven at about 30 RPS by an induction motor mounted within a weatherproof housing. The motor shaft also carries cam operated contacts to produce image spacing on the indicators, control signals for the Train Meter, and blanking during the lobe switch interval. The entire unit is gas tight and is filled with dry gas through the transmission line.

The value of the lobe switching capacitor and its position along the feed line must satisfy two conditions: first, the phase shift must be such that the antenna beam will be displaced by the desired amount; and second, the impedance at the feed point must be such that equal division of power will be obtained in the two halves of the array. In the first Radar Mark 3 antenna (6 ft. by 6 ft. parabolic array) a beam displacement of about 3.0

degrees was chosen as a suitable compromise between target angle sensitivity (steepness of beam) and reduction of signal amplitude "on target". This displacement required a phase shift of approximately 53 degrees between the two halves of the array. From transmission line theory it can be shown that this phase difference will be obtained with a capacitive reactance equal to the characteristic impedance of the feed line when connected at a point 0.176 wavelength from the feed point. It can also be shown that this condition satisfies the requirement for equal power division to the two halves of the array. A capacitor of the required value (about 3 micromicrofarads) can readily be built to withstand the peak transmitted power by proper condenser plate separation. A frequency variation of about 40 megacycles can be tolerated without materially affecting the antenna performance.

TABLE II.—Antenna Characteristics

	Radar Mark 3		Radar Mark 4
Dimensions	3' x 12'	6' x 6'	6' x 7'
Aperture in Wavelengths			
Azimuth	8.5	4.25	4.25
Elevation	2.1	4.25	4.95
Beam Width in Degrees (between half power points in one way pattern)			
Azimuth	6	12	12
Elevation	30	14	12
Antenna Gain in db	22.0	22.0	22.5
Beam Shift in Degrees			
Azimuth	$\pm 1.5^\circ$	$\pm 3.0^\circ$	$\pm 3.0^\circ$
Elevation			$\pm 3.0^\circ$

A lobe switching unit similar to that described above was also applied to the 3 ft. by 12 ft. antenna. Pertinent information regarding beam widths and lobing angles for both antennas (together with information on the antenna for Radar Mark 4 to be described later) is given in Table II.

The effective beam widths as used in these radars were somewhat narrower than the values given above due to the square law characteristic of the second detector in the receiver, and the deflection sensitivity was such that the specified tracking accuracy of ± 15 minutes of arc could readily be achieved. The "on target" position or axis of the antenna (lobe crossover) was carefully aligned with the optical telescopes at the time of installation so that either optics or radar angles could be used. The symmetrical design of the antenna made this alignment substantially independent of small changes in operating frequency.

To minimize target confusion the signals presented on the Train or Elevation Indicator (azimuth operator's oscilloscope) consisted only of

those received from the target being tracked by the range operator, all others being blanked out in the indicator circuits.

Accurate Range Measurement

The second major problem which required solution to adapt radar to the fire control problem was the provision of means for accurate and continuous range tracking. It was obvious that what was required was some sort of electronic range mark on the indicator sweeps, the position of which could be varied by a rotary device whose motion could be used to transmit range information to a remote point over a synchro system. The range mark could then be aligned with the target "pip" on the oscilloscope. For accurate data transmission it was necessary to obtain a linear relationship between angular rotation of the range handwheel and corresponding range to the marker on the radar indicator screen.

One method which was first employed by the Signal Corps made use of the fact that the transmitted pulses were generated at a periodic rate from a sine wave oscillator of fixed frequency; the pulse being produced at a fixed point in each cycle. By transmitting this same sine wave through a linear phase shifter a new pulse could be generated whose position in time, relative to the transmitted pulse, could be varied by rotation of the phase shifter. In the Signal Corps equipment a special goniometer was used to produce the phase shift and the accuracy obtained was considered adequate for the intended purpose. However, non-linearity of the phase shifting device, though small, was much greater than could be tolerated in the Navy fire control system. A study indicated that large scale manufacture of special phase shifters, hand adjusted to meet the stringent accuracy requirements was out of the question. It was therefore decided that a two speed system be used, in which the phase shifter errors would be divided by the gear ratio to the high-speed unit in much the same way that accurate synchro information is transmitted by a "coarse" and a "fine" synchro. The manner in which this was worked out by Bell Telephone Laboratories and applied to Radars Mark 3 and 4 is described below.

The method of range measurement can perhaps best be understood by first examining the method of presentation used on the cathode ray tube indicator for the range operator. This presentation is shown in Fig. 27 in which it will be noted that a Class A sweep is used to display the transmitted pulse and received echoes. This horizontal sweep, however, differs from the simple sweep of earlier radars in several respects. First, the central portion of the sweep is expanded to permit more accurate viewing of signals appearing within this region; second, a downward deflection called the range "notch" is produced in the approximate center of the expanded section; and third, the circuits are so arranged that the notch

remains centered as the range unit phase shifters are rotated thus causing all of the signals (rather than the notch) to move across the screen. Range measurement is made by rotating the range unit handcrank to place the desired signal in the center of the range notch on the indicator. This type of presentation has several advantages. It permits the full 100,000-yard range to be viewed at all times so that new targets may be immediately detected, and permits accurate viewing of the desired target in the expanded

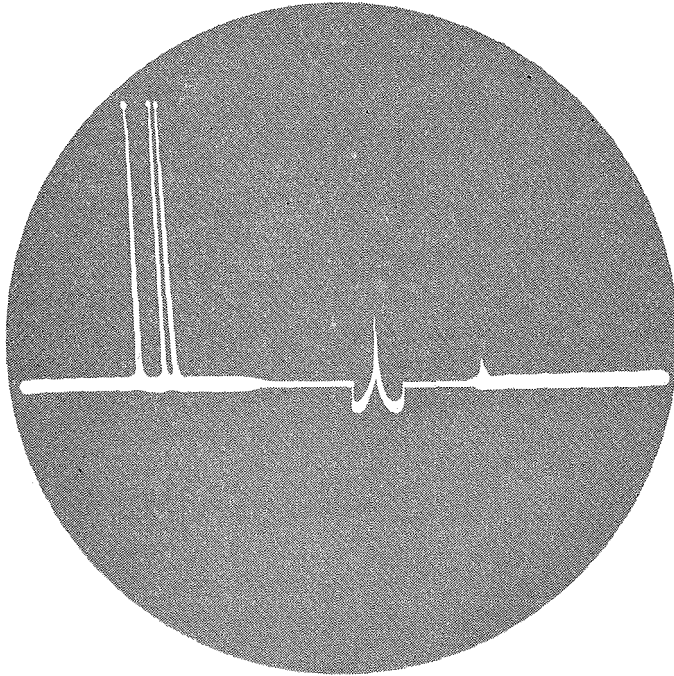

Fig. 27—Mark 3 & 4—Range presentation

center of the sweep where best focus is obtained. For smooth range tracking it is only necessary for the operator to rotate the range unit hand crank to keep the desired signal centered in the range notch.

A block diagram of the range measuring system, together with the circuits used to obtain the cathode ray indicator presentation described above, is shown in Fig. 28. A base or reference oscillator generates a sine wave of 1.639 kc, one cycle of which corresponds to a radar range of 100,000 yards. This wave, after amplification, is applied to a non-linear coil pulse generator⁸ which generates short pulses (one positive and one negative pulse

³ "Magnetic Generation of a group of Harmonics," E. Petersen, J. M. Manley, L. R. Wrathall—August 1937, *B. S. T. J.*, October 1937.

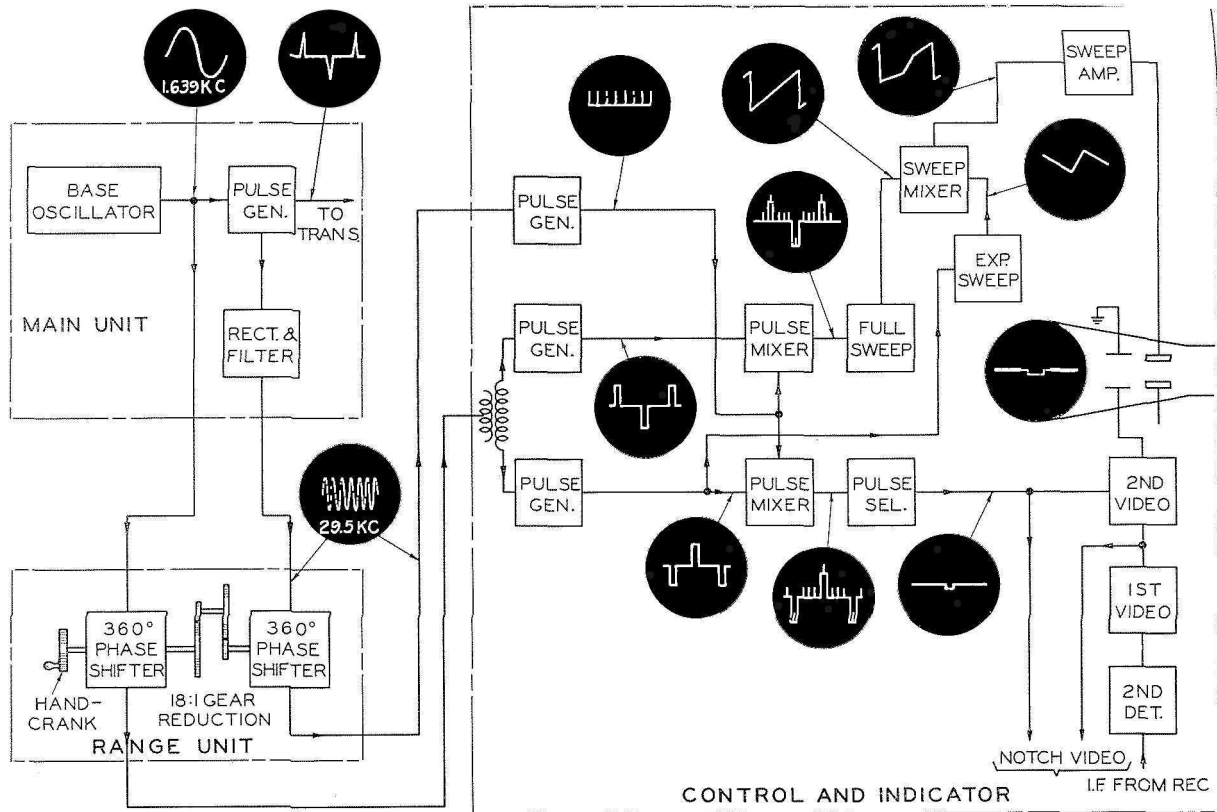

Fig. 28—Mark 3 & 4—Range measuring system

per cycle); the positive pulses being used for keying the transmitter. These pulses are rich in odd harmonics of the base oscillator frequency. By rectifying these pulses to reverse the negative pulses, even harmonics of the base frequency are obtained and the 18th harmonic (29.5 kc) is selected by means of a filter. This harmonic frequency and the original base frequency are applied to two phase shifters whose shafts are geared together in the ratio of 18 to 1. Since one revolution of the one speed phase shifter corresponds to 100,000 yards, one revolution of the 18-speed unit corresponds to only 5550 yards with the result that range errors caused by non-linearity of this phase shifter are reduced by a factor of 18. The phase shifters employed are similar to those designed by Bell Telephone Laboratories for use in a phase measuring bridge⁴ and are linear to within ± 1.5 degrees or about 0.4 per cent. The possible range error introduced by imperfections in the 18-speed phase shifter was therefore only 23 yards, well within the design requirements. It remains to be shown how this accurate range information was applied to the indicator.

The output of the 18-speed phase shifter in the range unit is connected to the Control and Indicator where the phase shifted sine wave is used to generate short, rectangular pulses of about 600 yards duration. One pulse is produced for each cycle of the 29.5 kc wave so that 18 of them occur during the 100,000-yard sweep interval. It is desired that only one of these pulses appear as a range notch on the indicator screen and this pulse is selected from the others by a pedestal pulse generated from the output of the one speed phase shifter. It will be noted that as the phase shifters are rotated by means of the range unit hand crank, the desired pulse from the 18-speed phase shifter will remain substantially centered on the one-speed pedestal pulse. After further shaping, the selected pulse is mixed with the received signals in the second video amplifier and is then applied to the vertical plates of the cathode ray indicator to form the "range notch". The range notch is also transmitted to the Train Indicator and Train Meter where it is used to prevent any signal from affecting those instruments except the one being tracked by the range operator.

Since it is desired to have the range notch appear in the center of the 100,000-yard sweep on the indicator, the sweep trigger pulse must occur 50,000 yards in advance of the notch. This trigger is obtained by selection of another pulse from the accurate phase shifter, this time using a one-speed pedestal produced by an input of reversed phase. The pulse thus selected is used as a trigger for starting a saw-tooth sweep wave with a duration corresponding to 100,000 yards radar range. Expansion of the center portion of this sweep is obtained by adding to this wave a second

⁴L. A. Meacham, U. S. Patent 2004613.

saw-tooth wave having maximum rate of change in the center of the sweep; the latter being derived from the range notch selection pedestal. The combined sweep is then applied to the horizontal plates of the cathode ray tube. The return trace is blanked by applying to the control grid of the cathode ray tube a voltage obtained by differentiating the sweep waveform.

Transmitter

As mentioned earlier the transmitter oscillator tube problem was one of the major obstacles in the march of radar development to higher frequencies. Intense development effort on many possible types of tubes was underway in several laboratories in this country and abroad during 1939

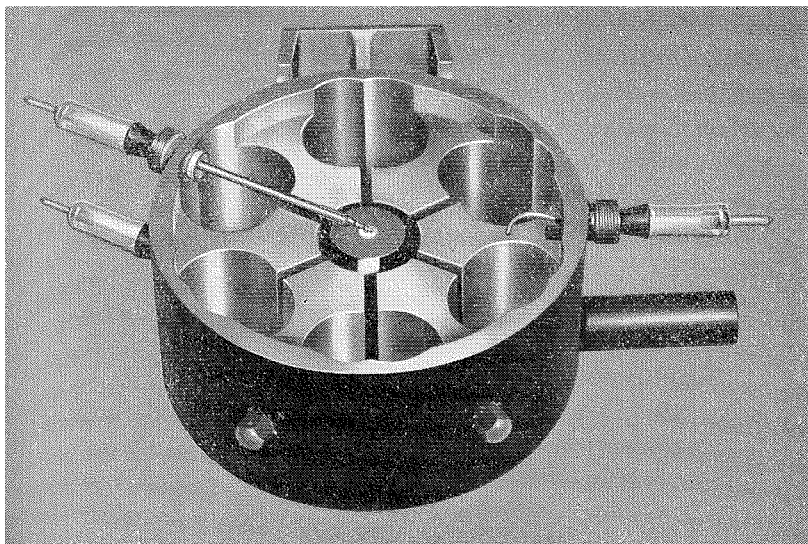

Fig. 29—W. E. 700-type magnetron—one side removed

and 1940. The first significant improvement came in England where work with multicavity magnetrons showed that this device was probably the answer to radar's need for a highly intermittent duty oscillator suitable for high power in the microwave region. A sample of this device was brought to this country by the Government and was tested in Bell Telephone Laboratories in October 1940. It produced pulses of several kilowatts at a frequency in the neighborhood of 3000 mc. A tremendous development of this device got under way immediately⁵ and the multicavity magnetron

⁵ "The Magnetron as a Generator of Centimeter Waves," J. B. Fisk, H. G. Hagstrum, and P. L. Hartman, *B. S. T. J.*, January, 1946.

became the key piece in the enormous development of radar equipment for still higher frequencies during the war. However, at the beginning of 1941 there were still many unsolved problems in 3000 mc radar other than that of the transmitter tube. On the other hand, the systems problems had been quite satisfactorily solved in the 700-mc region. The decision was therefore immediately made to extrapolate the British design down to

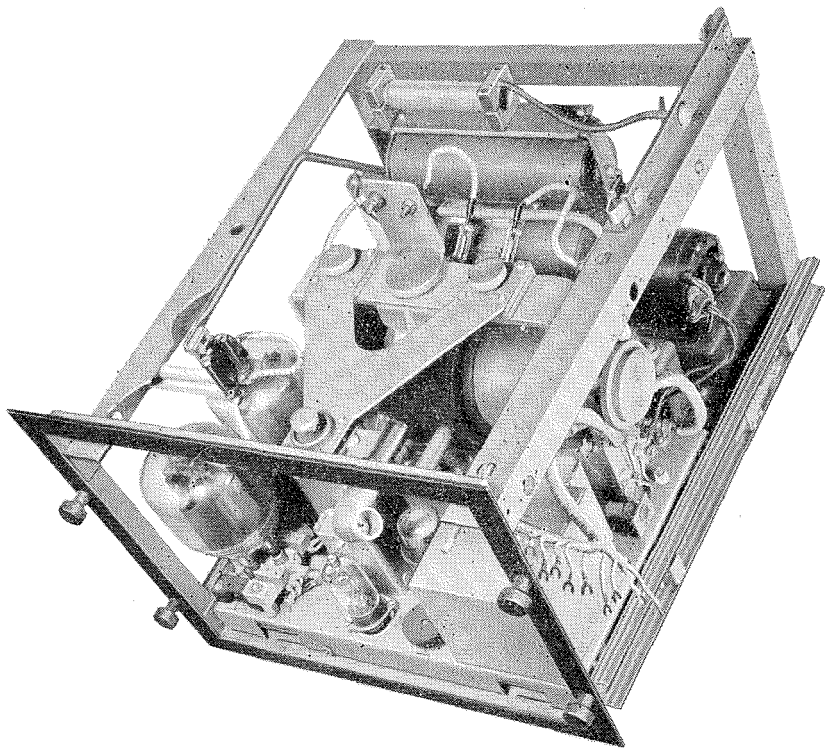

Fig. 30—Mark 3 & 4—transmitter

700 mc in order to obtain a higher powered and more satisfactory oscillator for the existing systems. This was done at top speed and a picture of the resulting tube is shown in Fig. 29. This was the first type of multi-cavity magnetron to go into production in this country. Concurrent with the design of the new magnetron the vacuum tube department of the Laboratories developed an improved tetrode modulator tube which was many times as efficient for radar pulse service as the triodes formerly used. This tube was designated W.E. 701-A.

A new transmitter using the magnetron and two of the new modulator

tubes was rushed through development and produced in time to go with the first accurate fire control radars. This transmitter provided a peak power output of about 40 kw with a pulse duration of 2 microseconds. It resulted in a material increase in reliable range, with satisfactory tube life. The new transmitter, shown in Fig. 30, was made mechanically interchangeable with the old and was applied retroactively also to the Mark 1 Radars.

Duplexing

The use of the high-power transmitter required additional protection for the receiver during the transmitted pulse in order to prevent damage

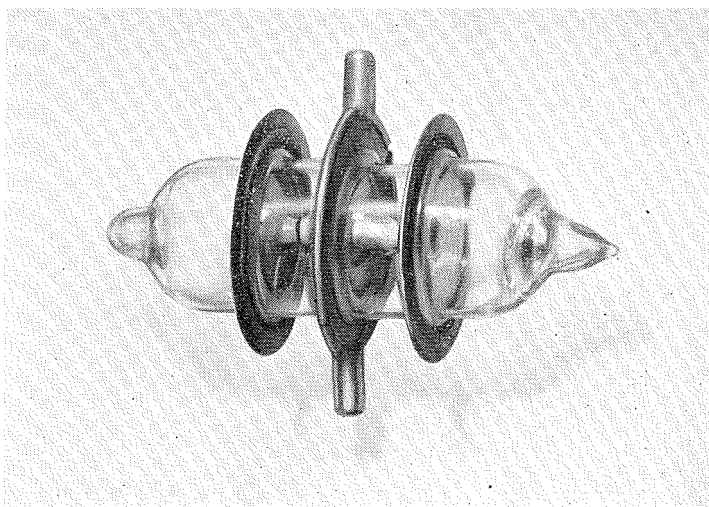

Fig. 31—W. E. 702—TR tube

and to permit the receiver to recover rapidly for reception of nearby echoes. The duplexing equipment was therefore modified to include a gas switching tube in the receiving transmission line. This was a refinement of the method used earlier by the Naval Research Laboratory.

The switching tube (W.E. 702A) was developed specifically for this purpose and is shown in Fig. 31. It was the first of the "TR" tubes of this general form and consists of a hydrogen-water vapor filled glass chamber with three copper electrodes.⁶ This tube was mounted in the center of a half-wavelength coaxial line short circuited at each end, the outer conductor being connected to the outer electrodes and the center conductor

⁶ "The Gas Discharge Transmit-Receive Switch," A. L. Samuel, J. W. Clark, and W. W. Mumford, this issue of *B. S. T. J.*

to the middle electrode. Input and output connections were tapped on this half-wave line near the short circuited ends. During reception this assembly introduces negligible loss in the receiving line. However, during the transmitted pulse a small amount of the transmitted power ionizes the gas in the switching tube and effectively short-circuits the receiver line. This device, which in later forms came to be called a "T-R Box", is located near the receiver input and the length of line between it and the junction with the transmitter line can be adjusted to an odd multiple of quarter wavelengths to present the desired high impedance at that point during transmission.

Receiver

The receiver delivered with early Mark 3 equipments was identical to that used in Radar Mark 1. It was of the superheterodyne type employing one stage of RF amplification (doorknob tube), 316A oscillator tube, and doorknob first detector. The intermediate frequency amplifier had a bandwidth of about 1 megacycle at a midband frequency of about 30 megacycles. The second detector and video stages were located in the indicating equipment. A photograph of this receiver is shown in Fig. 11.

Since in microwave work the controlling noise is that produced in the receiver, it is desirable to reduce this noise to the theoretical limit of thermal agitation in the input circuit. However, in 1939 tube limitations and circuit design techniques at these frequencies resulted in performance far short of this goal. The amount by which the receiver noise exceeds the theoretical minimum has been termed the receiver "noise figure" and in this early receiver the noise figure was about 24 db. It was recognized that considerable improvement in maximum range could be obtained by reducing this receiver noise.

Shortly after first deliveries of Radar Mark 3 a new tube (GL-446 or "lighthouse" tube) was made available by the General Electric Company which showed promise of providing a substantial improvement in the receiver noise figure. An amplifier using this tube was accordingly designed by Bell Laboratories in which coaxial cavities were used for tuning elements. Two stages of amplification were used to replace the single "doorknob" tube stage previously employed. The new amplifier resulted in a reduction of the receiver noise figure to about 9 db and provided a marked improvement in maximum range capability of the radar. These amplifiers were manufactured and shipped to the Fleet for field installations on early equipments and were included in productions on equipments shipped subsequently to availability of the amplifiers. A photograph of the receiver with the two amplifiers installed is shown in Fig. 32.

Another field modification provided automatic gain control of the signal

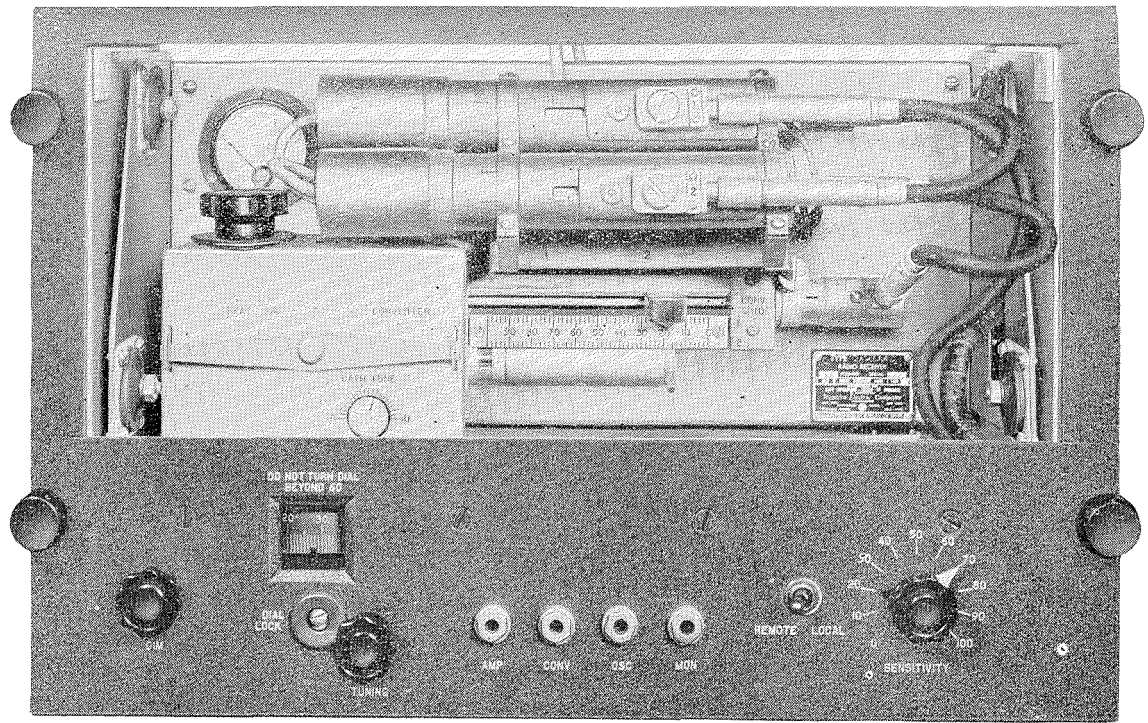

Fig. 32—Receiver—showing improved R. F. amplifier

selected by the range operator. This was supplied in the form of an external unit which controlled the gain of the receiver IF amplifier to reduce signal fluctuations produced by fading.

The first production Mark 3 Radars were delivered to the Navy in October 1941, and the first two installations were completed on the main battery directors of the U.S.S. Philadelphia at the Brooklyn Navy Yard that month.

RADAR MARK IV

During the development work on Radar Mark 3 the Navy pointed out the need for a fire control radar for use with the 5-inch Naval guns against enemy aircraft. The Bell Telephone Laboratories was therefore requested to further modify the radar design to meet this need. The anti-aircraft equipment was first designated FD, later becoming known as Radar Mark 4.

For anti-aircraft fire control a new coordinate had to be added to the target-locating system; namely, elevation angle. Again it was desired that the additional information be obtained from the single antenna with a precision equal to that already obtained in azimuth. This problem was approached in a manner similar to that used for the Mark 3 antenna and is described below.

Two Plane Lobe Switching

In considering two plane lobe switching methods it appeared that the desired result could be obtained by mounting two 3 ft. x 6 ft. parabolic arrays one above the other. This arrangement was tried and resulted in the array shown in Fig. 33. It provided two plane lobe switching with an antenna only slightly larger than the 6 ft. x 6 ft. antenna used before and had comparable gain and beam width (see Table II).

A schematic diagram of the array is shown in Fig. 34. Here it will be seen that there are two horizontal dipole arrays, each mounted along the focal line of a cylindrical parabola. The dipoles are in four groups and the interconnecting harness is criss-crossed and joined to the feed line at the center. Symmetrically placed around the feed point are four stub lines connected to the lobe switcher stators. Here again a semi-circular rotor is used for the lobe shifting capacitor. It will be observed that during each quarter turn of the rotor two stator plates are engaged, and the sequence is such that the beam shifts left, up, right, and down during one rotation. A separate Indicator was provided for the Pointer (elevation operator). To avoid signal confusion on the two Indicators it is necessary to show only left-right signals on the Trainer's oscilloscope and up-down signals on the Pointer's oscilloscope. This is accomplished by means of cam operated contacts in the lobe switcher which blank the indicators during the required

intervals. Other contacts on this assembly provide left-right and up-down image spacing.

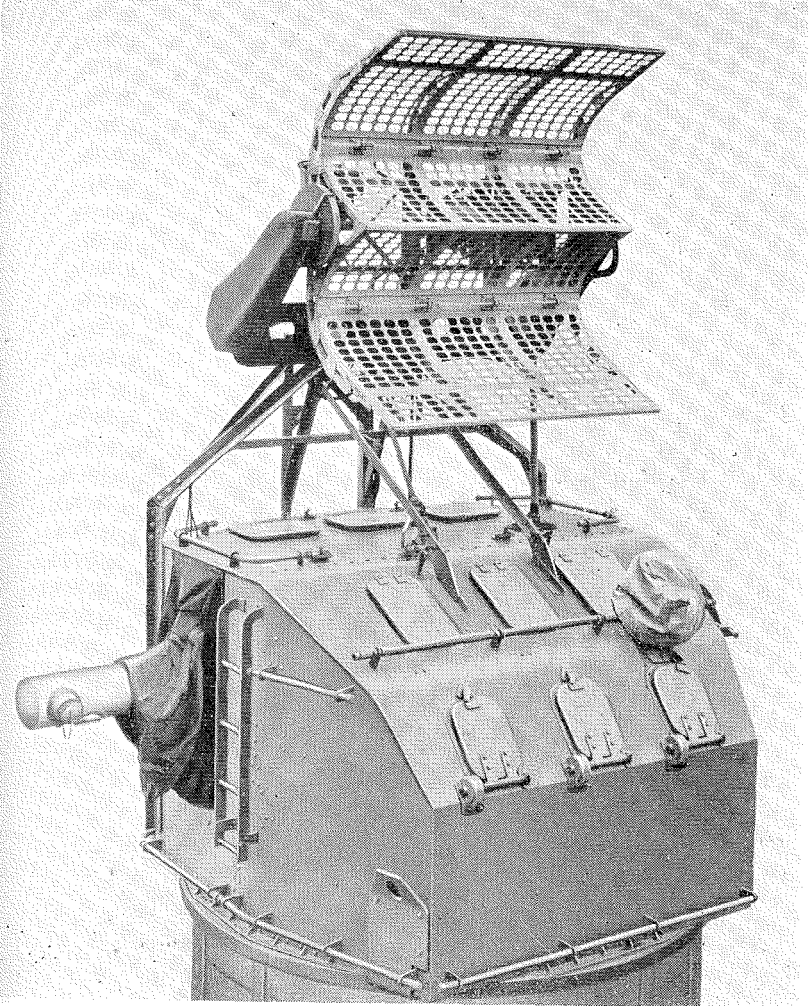

Fig. 33—Mark 4—antenna on gun director

Except for the new antenna and the additional Train or Elevation Indicator for the Pointer (elevation operator), this radar was identical to Radar Mark 3. The first demonstration of a development model of Radar Mark 4 was made at Atlantic Highlands, New Jersey, in September 1941 and this model was installed aboard the destroyer U.S.S. *Roe* the latter

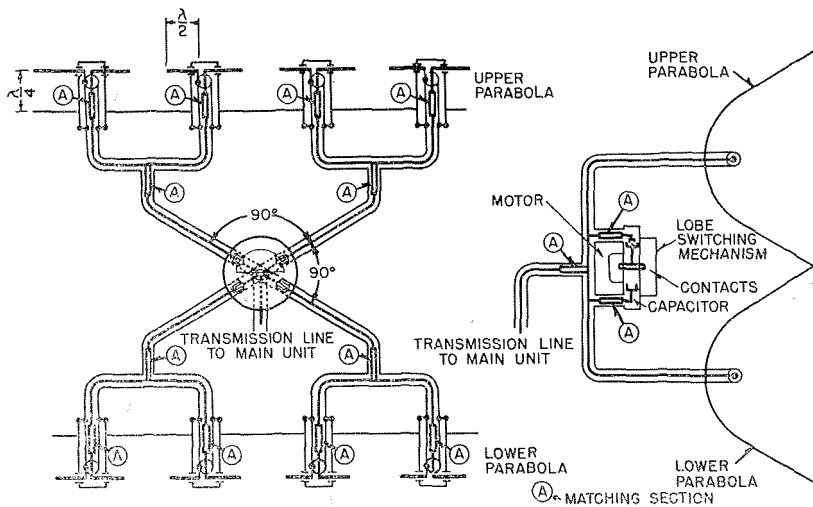

Fig. 34—Mark 4—Antenna schematic



Fig. 35—Mark 4 antenna on Battleship Tennessee (Navy Photo 1908-43)

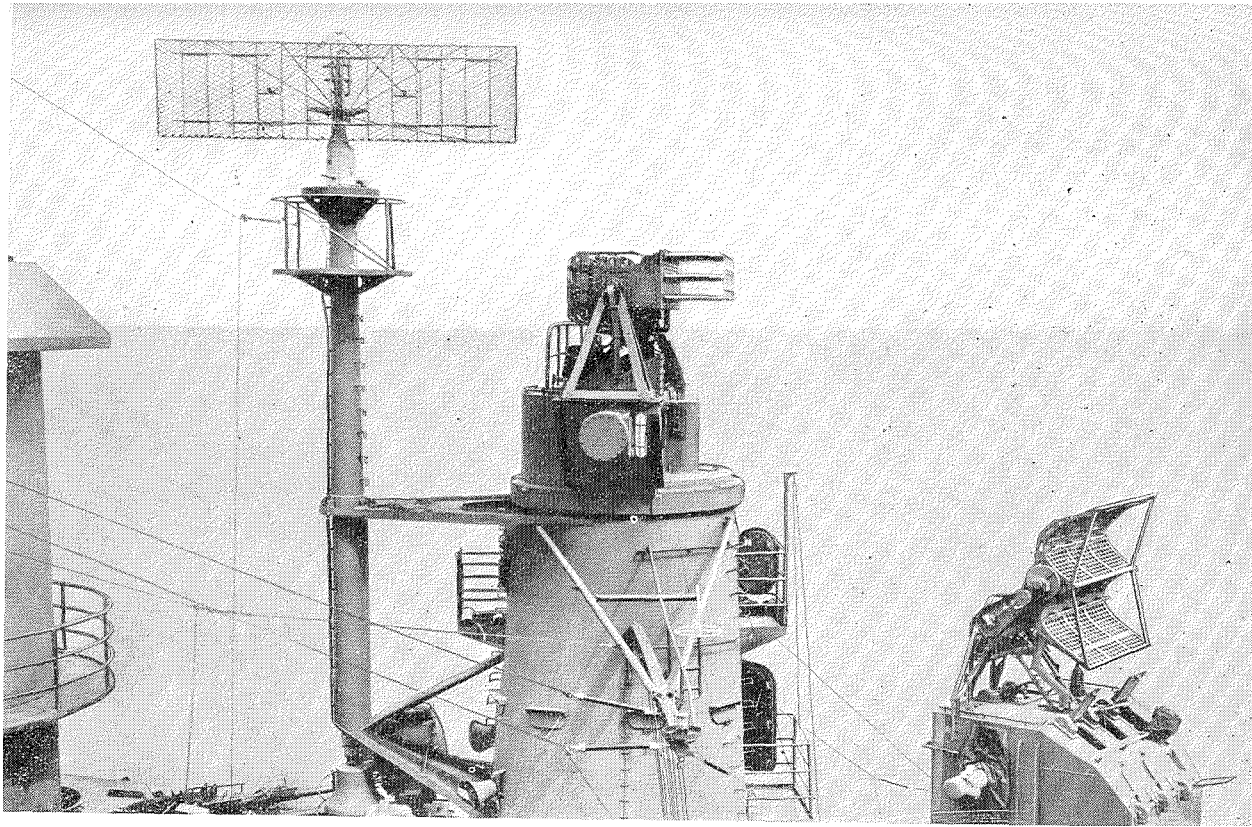

Fig. 36—Radar antennas on Battleship Tennessee (Navy Photo 1905-43)

part of that month. Initial production deliveries of these radars were made in December 1941.

Typical installations of the Mark 4 Antenna on the secondary battery directors of a battleship are shown in Figs. 35 and 36. The main frame installation for Mark 3 and Mark 4 on a battleship is shown in Fig. 37

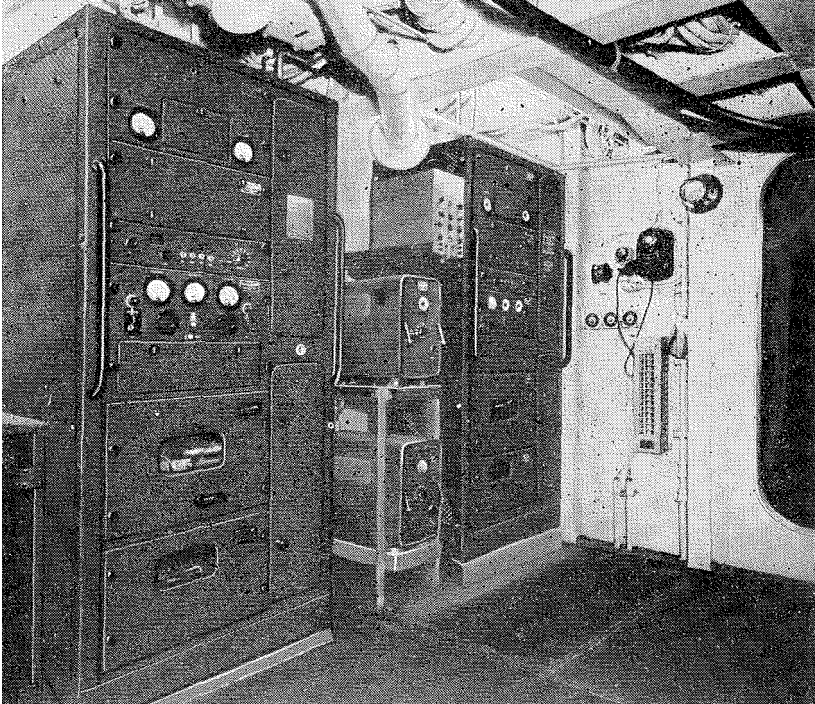

Fig. 37—Radars Mark 3 & 4—main units on Battleship New Jersey (Navy Photo 181809)

while typical installations of the train and elevation operator's units in the director are shown in Figs. 38 and 39.

APPLICATION AND USE OF MARK 3 AND 4 RADARS

The Mark 3 radars, designed for use against surface targets only, were generally installed on the main battery directors of battleships and cruisers. The Mark 4 radars for use against either surface targets or aircraft were generally installed on the secondary battery directors of battleships and cruisers, and on the one and only dual purpose director on destroyers. Thus a battleship usually had two Mark 3 and four Mark 4 equipments and a destroyer one Mark 4. Practically every ship in the fleet, of destroyer

size or larger, was equipped with one or more of these equipments early in the war. A total of 139 Mark 3, and 670 Mark 4 radars were built, including those used ashore at schools. Although some of these equipments were replaced by more modern designs before the end of the war and some were lost in battle, there were still approximately 85 Mark 3 and 300 Mark 4

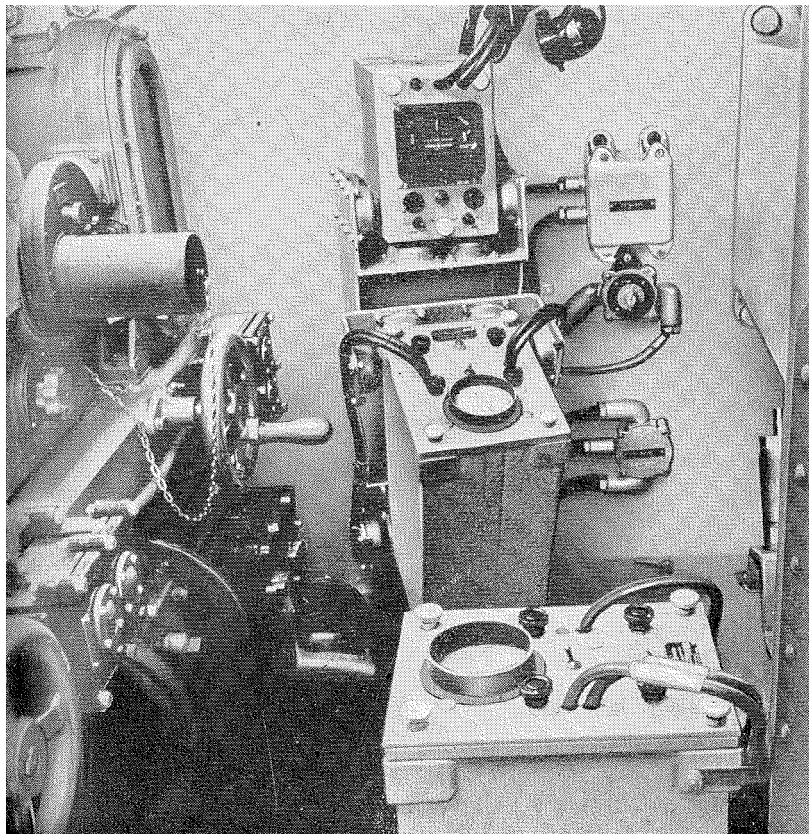

Fig. 38—Mark 4 Radar—trainer & pointer operators' positions on Aircraft Carrier Saratoga (Navy Photo 177347)

radars in service in the fleet on V-J day. The first four Mark 4's, Serial Nos. 1, 2, 3 and 5 installed on the battleship Washington were used until the middle of 1945, although newer designs had been going on all new vessels for more than a year.

These early equipments were the "guinea pigs" of fire control radar. They were the instruments with which our fleet learned to fight effectively

at night and thereby gain a large advantage over the enemy whose radar was feeble and inaccurate. They played a part in every one of the early battles and most of the later ones in the Pacific. They controlled the cruiser Boise's guns in October 1942, when she blazed away at night at a vastly superior fleet in the Solomons and made the enemy pay 10 to 1 for the

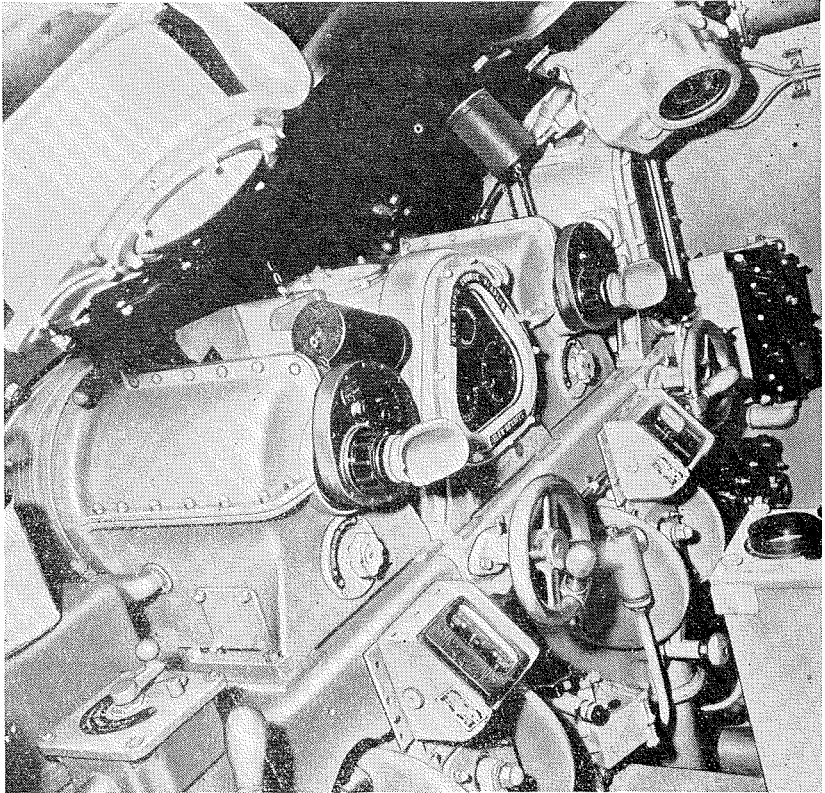

Fig. 39—Radar Mark 4—trainer & pointer operators' positions on Destroyer Barton (Navy Photo 181775)

damage they succeeded in doing. They were with the cruiser San Francisco on a night in November 1942, when a small U. S. force sank 27 enemy ships, almost completely destroying a large Japanese convoy bound for Guadalcanal when our hold there was at best precarious. The Mark 3 steered the big guns of the battleship South Dakota in the Solomons on the dark night of November 4, 1942, when she sank a major Japanese war vessel eight miles away with two salvos. Even in engagements in broad daylight when optics could be used for target angles these radars still played a vital

part in furnishing accurate range which made 5" gunfire against aircraft, for example, deadly at long range. Thus on October 16, 1942, when the South Dakota was attacked by planes she shot down an even 38 out of 38 attacking.

The rapid and widespread application of this rather complex electronic equipment was not accomplished without pain and confusion. It is beyond the scope of this paper to discuss the enormous problem of training in operation and maintenance that had to be solved, or of the tactical revolution in Naval warfare that fire-control radar produced. It is sufficient here to say that these and other problems were solved by heroic efforts of hundreds of officers and civilians in the Navy Department ashore and the thousands of officers and men of the fleet. Their problems were made more difficult by weaknesses in the equipment which were revealed by battle experience as the new science of radar got its baptism of fire. In every possible case the Laboratories attempted to remove the causes of recurring troubles by redesign and the furnishing of improvement kits of parts for installation in the fleet. The many lessons of experience learned from the Mark 3's and 4's were immediately applied in the design of the many more modern radars for the same and other types of service.

The authors of this paper wish to express their gratitude to the many Navy men with whom they have worked in connection with these equipments, and whose whole-hearted cooperation during difficult times made possible the successful development of these fire-control radars. They also wish to thank their colleagues in Bell Telephone Laboratories who worked as a team to make this important equipment possible, and the men of the Western Electric Company for their help on the many engineering problems which arose during production and use in the field. It is the hope of all who were concerned with this development that accurate radars, like other radars, will find peaceful use in a peaceful world, but it is also the determination of these engineers that as long as we need a Navy, we will try to provide it with radars as much superior to those of any possible enemy as they were in the recent war.